



2021 LEAF

Dismantling Guide



zero Emission

Foreword

This manual describes dismantling operations and **important safety** related warnings for this vehicle.

This vehicle is an electrically driven car equipped with a high-voltage battery pack. **Failure to follow recommended practices during dismantling will cause death or serious personal injury.**

Please read this manual in advance in order to understand the features of this vehicle and to help you deal with dismantling operations involving this vehicle. Follow the procedures in order to help assure a safe and successful dismantling operation.

This manual is periodically updated. If you are not viewing this manual on the Nissan web site, we urge you to go to www.nissanusa.com or www.nissan-techinfo.com to make sure you have the most recent version of this manual.

NISSAN EMERGENCY CONTACT INFORMATION

- Nissan EV Customer Support: 1-877-664-2738
- Nissan Consumer Affairs: 1-800-647-7261 (US) or 1-800-387-0122 (Canada)

IMPORTANT INFORMATION ABOUT THIS MANUAL

You may see various symbols in this manual. They have the following meanings:



This symbol is used to inform you of an operation which will result in death or serious personal injury if instructions are not followed.

Example: Touching high-voltage components without using the appropriate protective equipment will result in electrocution.



This symbol is used to inform you of an operation which may cause death or serious personal injury if instructions are not followed.



This symbol is used to inform you of an operation which may cause personal injury or component damage if instructions are not followed.

Please note that there may be differences between this manual and the vehicle specification due to specification changes.

Table of Contents

FOREWORD	DG-2
NISSAN EMERGENCY CONTACT INFORMATION	DG-2
IMPORTANT INFORMATION ABOUT THIS MANUAL	DG-2
1. ABOUT THE NISSAN LEAF®	DG-5
1-1 LEAF IDENTIFICATION	DG-6
1-1.1 EXTERIOR	DG-6
1-1.2 INTERIOR COMPONENT LOCATION	DG-7
1-2 VEHICLE IDENTIFICATION NUMBER (VIN) LAYOUT	DG-8
1-3 WARNING AND INDICATOR LAMP INFORMATION	DG-9
2. BASIC HIGH-VOLTAGE INFORMATION	DG-10
2-1 HIGH-VOLTAGE-RELATED AND 12-VOLT-RELATED COMPONENT LOCATIONS AND DESCRIPTIONS	DG-10
2-1.1 HIGH-VOLTAGE BATTERY PACK SPECIFICATIONS	DG-12
2-2 HIGH-VOLTAGE SAFETY MEASURES	DG-12
2-2.1 WARNING LABELS	DG-12
2-3 HIGH-VOLTAGE CIRCUIT SHUT-OFF SYSTEM	DG-14
2-4 PREVENTING ELECTRICAL SHOCK	DG-14
3. PREPARATION FOR DISMANTLING	DG-15
3-1 DISCHARGING PROCEDURES	DG-15
3-2 PREPARATION ITEMS	DG-18
3-3 PERSONAL PROTECTIVE EQUIPMENT (PPE) AND INSULATED TOOLS	DG-19
3-3.1 PERSONAL PROTECTIVE EQUIPMENT (PPE) PROTECTIVE WEAR CONTROL	DG-19
3-3.2 DAILY INSPECTION	DG-19
3-3.3 INSULATED TOOLS	DG-19
3-4 HIGH-VOLTAGE SYSTEM SHUT-DOWN PROCEDURES	DG-19
3-4.1 REMOVING THE CHARGE CONNECTOR	DG-21
3-4.2 INDICATIONS THE HIGH-VOLTAGE SYSTEM IS ON	DG-23
3-4.3 POWERING DOWN THE HIGH-VOLTAGE SYSTEM	DG-23
3-4.4 PRIMARY PROCEDURE	DG-24
3-4.5 ALTERNATE PROCEDURE 1 (REMOVE FUSES)	DG-25
3-4.6 ALTERNATE PROCEDURE 2 (REMOVE SERVICE PLUG)	DG-27

3-5	CUTTING THE VEHICLE BODY	DG-29
3-5.1	SRS AIR BAG SYSTEM COMPONENTS LOCATION	DG-30
3-5.2	VEHICLE CUT SHEET	DG-31
3-5.3	WATER SUBMERSION	DG-32
3-5.4	VEHICLE FIRE	DG-32
3-6	HIGH-VOLTAGE BATTERY DAMAGE AND FLUID LEAKS	DG-33
4.	JUMP STARTING	DG-34
4-1	JUMP STARTING PROCEDURES	DG-35
4-2	ELECTRIC PARKING BRAKE RELEASE PROCEDURES	DG-36
4-2.1	RELEASING ELECTRIC PARKING BRAKE USING PARKING BRAKE SWITCH ...	DG-36
4-2.2	RELEASING ELECTRIC PARKING BRAKE WHERE PARKING BRAKE SWITCH CANNOT BE USED	DG-37
4-3	P (PARK) POSITION RELEASE PROCEDURE	DG-38
4-3.1	RESET PROCEDURE	DG-38
4-4	STORING THE VEHICLE	DG-38
5.	DISMANTLING INFORMATION	DG-40
5-1	PRECAUTIONS FOR HANDLING HIGH-VOLTAGE BATTERY	DG-40
5-2	HIGH-VOLTAGE BATTERY PACK REMOVAL	DG-42
5-2.1	EXPLODED VIEW: 40 KWH HIGH-VOLTAGE BATTERY	DG-42
5-2.2	REMOVAL PROCEDURE: 40 KWH HIGH-VOLTAGE BATTERY	DG-43
5-2.3	EXPLODED VIEW: 62 KWH HIGH-VOLTAGE BATTERY	DG-48
5-2.4	REMOVAL PROCEDURE: 62 KWH HIGH-VOLTAGE BATTERY	DG-49
5-3	RECOVERY/RECYCLING OF THE HIGH-VOLTAGE BATTERY	DG-54

1. About The Nissan LEAF®

This vehicle uses two types of batteries. One is a 12-volt battery that is the same as the battery in vehicles powered by internal combustion engines, and the other is the high-voltage battery for the traction motor which propels the vehicle. The high-voltage battery is encased in steel and mounted underneath the vehicle.

The vehicle must be plugged-in in order for the high-voltage battery to be recharged. Additionally, the vehicle system can recharge the high-voltage battery by converting driving force into electricity while the vehicle is decelerating or being driven downhill. This is called regenerative charging. This vehicle is considered to be an environmentally friendly vehicle because it does not emit exhaust gases.

1-1 LEAF Identification

1-1.1 Exterior

The specific exterior identification features are indicated as follows:

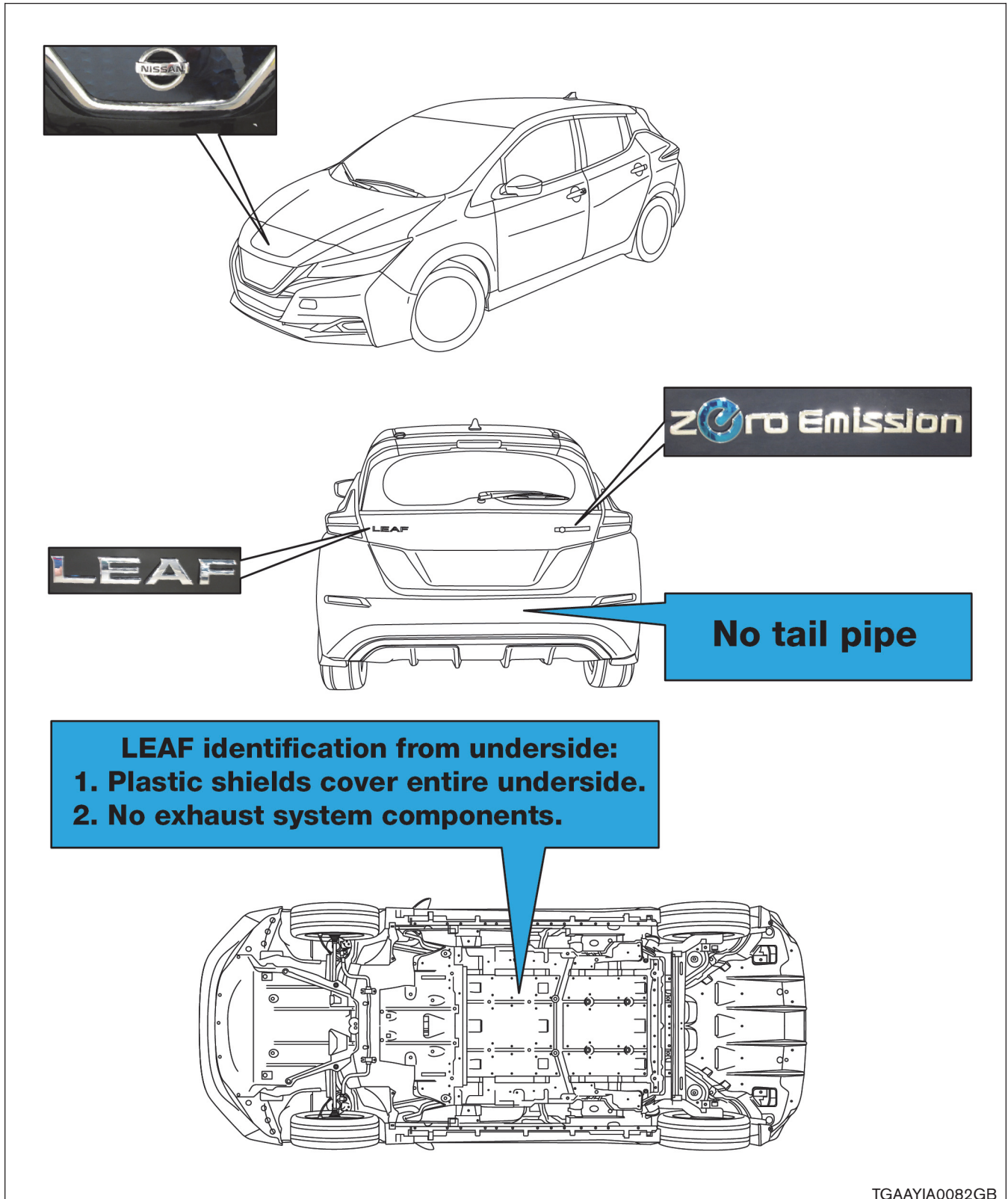

1-1.2 Interior Component Location

Interior components referenced in this manual are as follows:

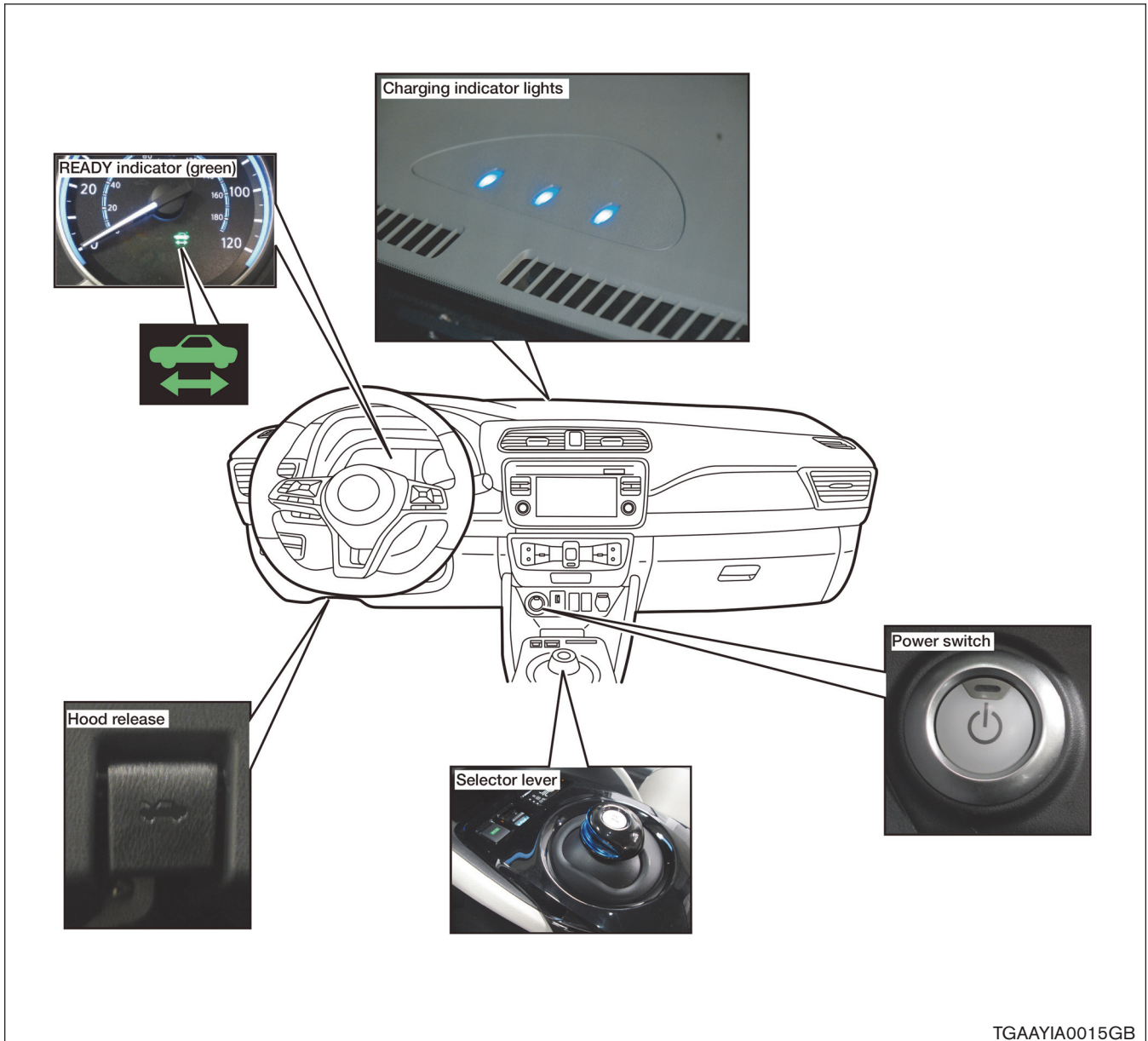

1-2 Vehicle Identification Number (VIN) Layout

The vehicle identification number can be located as follows: Example VIN : 1N4**A/BZ**1CPXMC053500

The High-voltage battery type is identified by the 4th alphanumeric character: **A** or **B**

A = 40 kWh Battery

B = 62 kWh Battery

The LEAF is identified by the 5th alphanumeric character: **Z**

Z = Electric vehicle

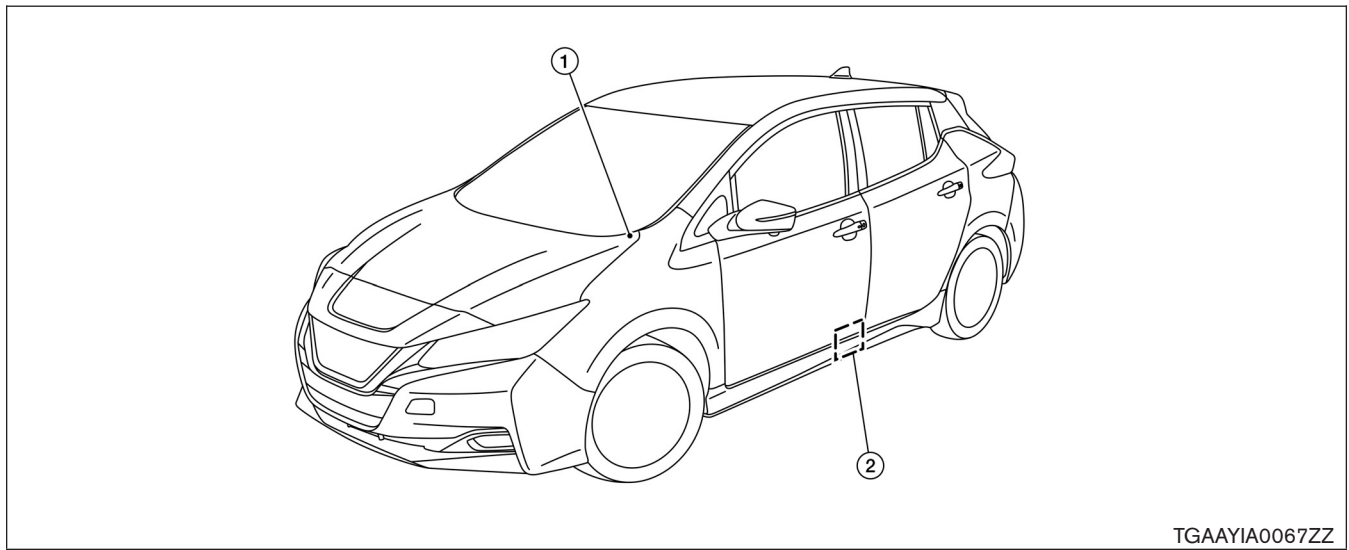





1. VIN plate (visible through windshield)

2. Vehicle certification label (lower center pillar)

1-3 Warning and Indicator Lamp Information

The following warning and indicator lamps are located in the instrument cluster.

Lamp Name	Icon	Description
READY Indicator		This lamp is on when the EV system is powered up and the vehicle is ready to drive.
EV System Warning Lamp*1		<ul style="list-style-type: none"> ▪ Malfunction has occurred in the EV system and/or ▪ Emergency shut-off system has been activated. The shut-off system activates in the following conditions: <ul style="list-style-type: none"> – Front and side collisions in which the air bags are deployed. – Certain rear collisions. – Certain EV system malfunctions.
Master Warning Lamp (RED)		This lamp is on when another red warning lamp is displayed in the instrument cluster or a warning is displayed on the vehicle information display.
Master Warning Lamp (YELLOW)		This lamp is on when: <ul style="list-style-type: none"> ▪ High-voltage battery is getting low on charge. ▪ A yellow warning lamp is displayed in the instrument cluster or a message is displayed on the vehicle information display.

*1: The READY indicator light will turn off in certain EV system malfunctions.

2. Basic High-Voltage Information

2-1 High-Voltage-Related and 12-volt-Related Component Locations and Descriptions

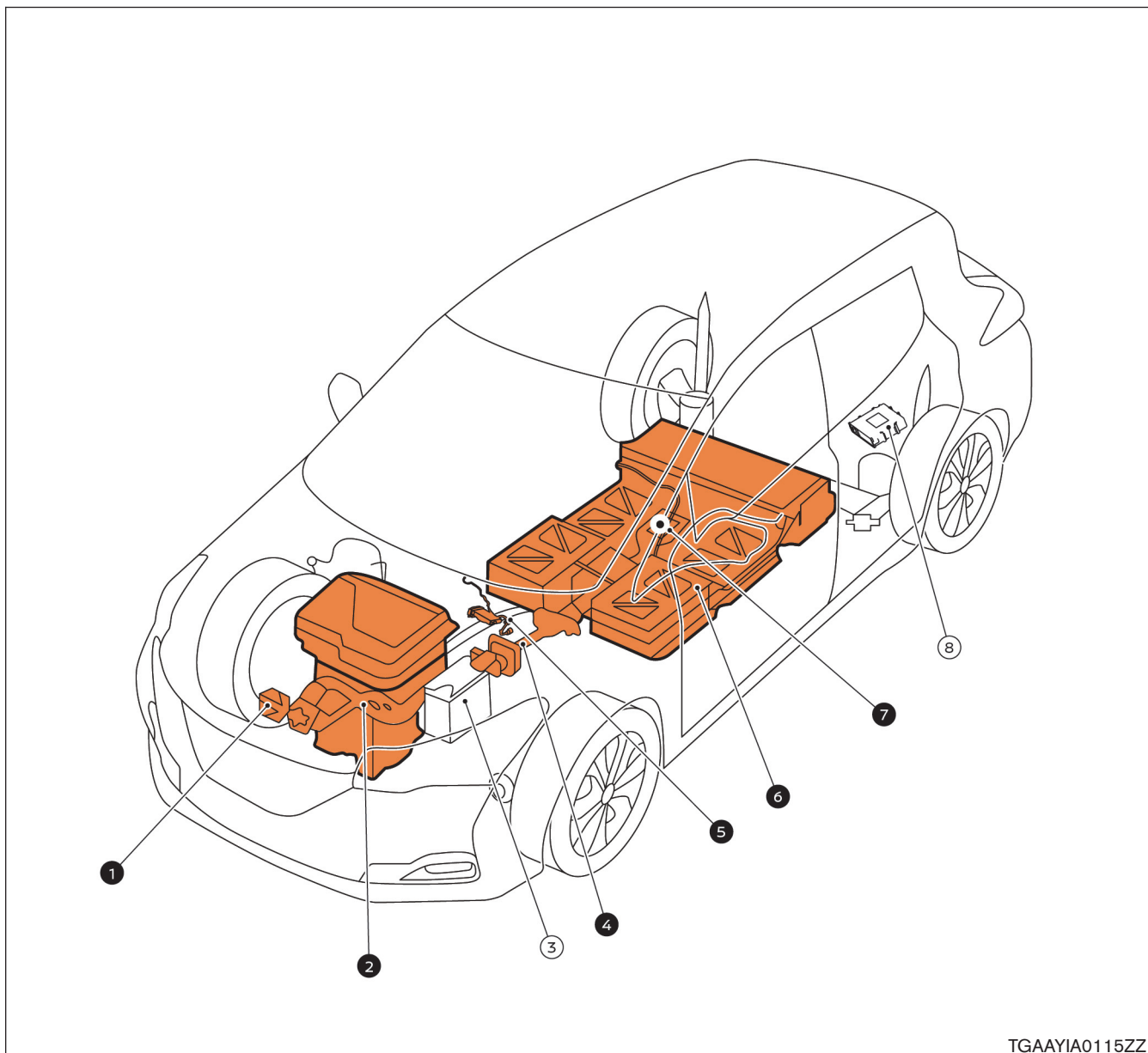

TGAAYIA0115ZZ

NOTE:

Components with white number in black background are high-voltage components.

No.	Component	Location	Description
①	Charge port	Under hood	Connecting port for EVSE (Electric Vehicle Supply Equipment). Two ports are available: Normal charge and quick charge (if so equipped).
②	Traction Motor	Under hood	Converts three-phase AC power to drive power (torque) which propels the vehicle.
	Inverter	Under hood	Converts the DC power stored in the high-voltage battery to three-phase AC power and controls motor torque (revolution) by regulating the motor current.
	Electric air conditioner compressor	Under hood	Air conditioner compressor
	Power Delivery Module (PDM) <ul style="list-style-type: none"> ▪ On Board Charger ▪ DC/DC Converter ▪ High-voltage junction box (J/B) 	Under hood	The PDM includes an On Board Charger, DC/DC converter and high-voltage junction box (J/B). The On Board Charger converts single-phase AC power from a home power outlet to DC power and increases the voltage in order to charge the high-voltage battery. The DC/DC converter reduces the voltage of the high-voltage battery to provide power to the 12-volt battery in order to operate the vehicle's electric components (headlights, audio system, etc.). The J/B provides electric power from the high-voltage battery to all high-voltage parts of the vehicle.
③	12-volt Battery	Under hood	A lead-acid battery that supplies power to the low voltage devices.
④	High-voltage cables	Under hood and undercarriage	Orange-colored power cables carry high-voltage current between each of the high-voltage components.
⑤	Cabin heater	Interior (This unit is installed behind the instrument panel)	This is the electric heat source for the cabin heater. It heats the interior of the vehicle.
⑥	High-voltage battery	Undercarriage	Stores and outputs DC power (Maximum voltage 420V) needed to propel the vehicle.
⑦	High-voltage battery service disconnect	Rear seat floor	Isolates the battery from the rest of the high-voltage electrical system.
⑧	Brake power supply backup unit	Cargo area (This unit is installed behind a trim panel to prevent access)	Power supply backup unit for the brake system. It supplies power to the brake system if a malfunction occurs in the 12-volt battery.

2-1.1 High-Voltage Battery Pack Specifications

High-voltage battery voltage	(240V - 420V usable range)
Number of high-voltage battery modules in the pack	24
High-voltage battery dimensions	60.90 x 46.77 x 10.39 in. (1547 x 1188 x 264 mm)
High-voltage battery weight	668.1 lbs (303 kg)

2-2 High-Voltage Safety Measures

Circuit insulation	The high-voltage positive (+) and negative (-) circuits are insulated from the metal chassis.
Reducing the risk of electrocution	The high-voltage components and harnesses have insulated cases or orange-colored coverings which provide insulation and easy identification. The high-voltage battery case is electrically connected to the vehicle ground. This connection helps protect the vehicle occupants and vehicle dismantlers from high-voltage electrical shock.
Identification	The high-voltage components are labeled "WARNING" similar to the label shown below. All high-voltage harnesses are coated in orange.

2-2.1 Warning Labels

The following warning label is applied to the power delivery module (PDM) located under hood.

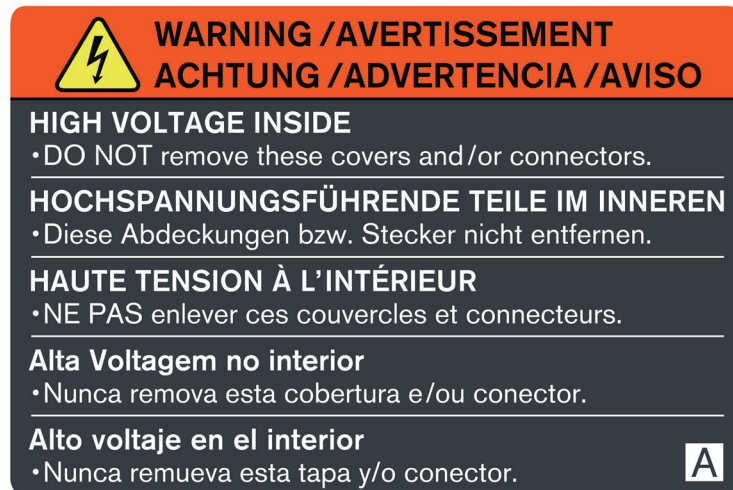

TGAAYIA0055ZZ

The following warning label is applied to the service plug access cover located in the rear seat floor.

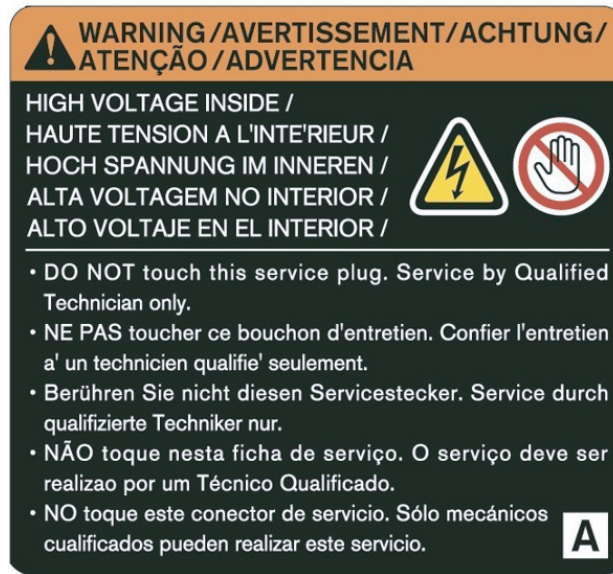

AAYIA0455ZZ

The following warning label is applied to the high-voltage battery located on the vehicle's undercarriage.



AAYIA0456ZZ

2-3 High-voltage Circuit Shut-Off System

The high-voltage can be shut off by the following methods:

Service plug	Positioned in the center area of the high-voltage battery, this shuts off output high-voltage when manually removed.
System main relay (located in high-voltage battery)	Controlled by the power switch, this relay, which is controlled by the 12-volt system, shuts off the high-voltage from the high-voltage battery.
Emergency shut-off system	In the case of a collision (front and side collisions in which the air bags are deployed, certain rear collisions) or certain system malfunctions this system is designed to shut off the high-voltage from the high-voltage battery.
Charging connector	Some of the high-voltage components are activated during charging. Remove the charging connector to deactivate these components.



2-4 Preventing Electrical Shock

1. If it is necessary to touch any of the high-voltage harnesses or components, you must always wear appropriate Personal Protective Equipment (PPE) (refer to [3-2 Preparation Items \(DG-18\)](#)) and shut off the high-voltage system by referring to [3-4 High-voltage System Shut-Down Procedures \(DG-19\)](#).
2. To avoid the risk of electrocution, NEVER touch the inside of the high-voltage battery unless appropriate PPE is worn even after shutting off the high-voltage system. The high-voltage battery maintains charge even though the high-voltage system is shut down.
3. Cover any damaged high-voltage components with insulated tape.







3. Preparation for Dismantling



DANGER

-  Failure to properly shut down the high-voltage electrical system before the Dismantling Procedures are performed will result in serious injury or death from electrical shock. To prevent serious injury or death, **NEVER** touch high-voltage harnesses or components without always wearing appropriate Personal Protective Equipment (PPE).
-  If it is necessary to touch any of the high-voltage harnesses or components you must always wear appropriate PPE to avoid electrical shock. Shut down the high-voltage system by following the steps outlined in [3-4 High-voltage System Shut-Down Procedures \(DG-19\)](#). Wait at least ten (10) minutes for complete discharge of the high-voltage capacitor after the high-voltage system has been shut down.

WARNING

-  **NEVER** assume the LEAF is shut OFF simply because it is quiet.
-  If it becomes necessary for the dismantler to leave the vehicle, place a “DANGER” sign (for example, refer to [4-4 Storing the Vehicle \(DG-38\)](#)) on the vehicle to alert other people that the vehicle contains a high-voltage battery.
-  If the READY  indicator or charging indicator are ON, the high-voltage system is active.
-  If possible, be sure to verify that the READY  indicator on the instrument cluster is OFF and the high-voltage system is stopped.

3-1 Discharging Procedures



DANGER

Do not perform this procedure if the high-voltage battery is damaged. If you are unsure of battery damage, use extreme caution and always wear appropriate Personal Protective Equipment (PPE) when working on high-voltage components.

High-voltage battery discharging must take place before dismantling. Sufficient discharging can be achieved by following these steps.

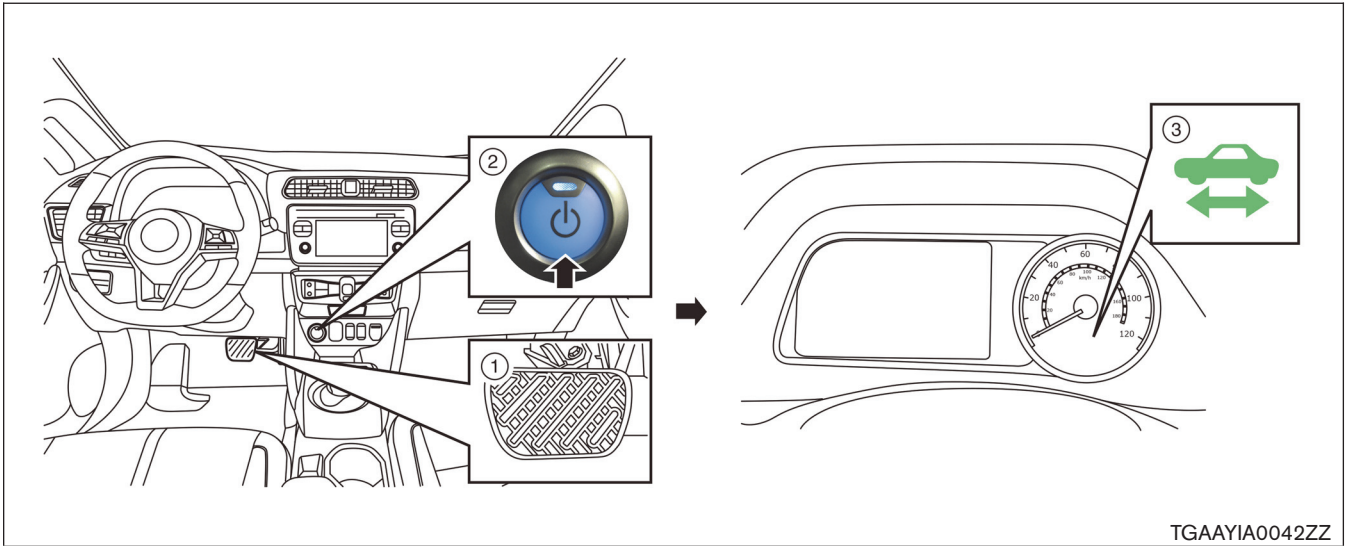

1. Place the selector lever into the Park (P) position.
2. Apply the parking brake.
3. Set wheel chocks to ensure the vehicle is completely immobilized.

4. Apply brake pedal (1) and press the power switch (2) to turn the system ON. Confirm READY indicator (3) in instrument cluster turns ON.

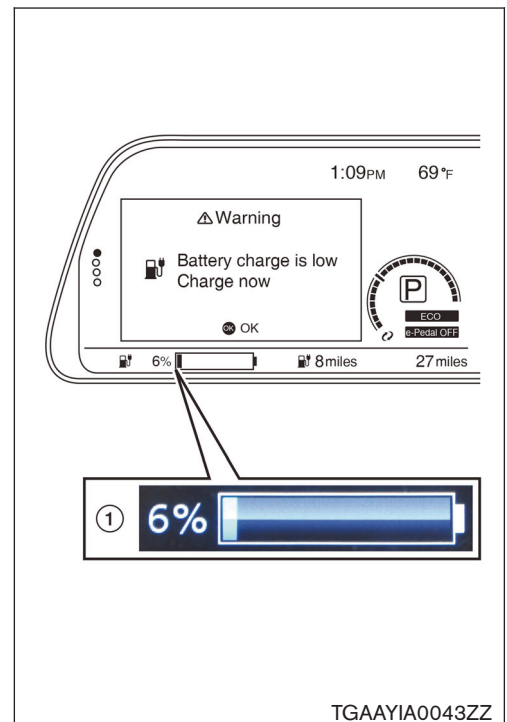

5. Turn ON electric devices such as headlamps, cabin heater (set to the highest temperature and maximum fan speed; do not use AUTO A/C setting), navigation system and rear window defroster to discharge the high-voltage battery.
6. Monitor high-voltage battery available charge gauge (1) in the vehicle information display.



7. Discharge is complete when the READY  indicator and orange electric vehicle (EV) system warning  indicator both turn off and message is displayed "Push brake and power switch to drive".

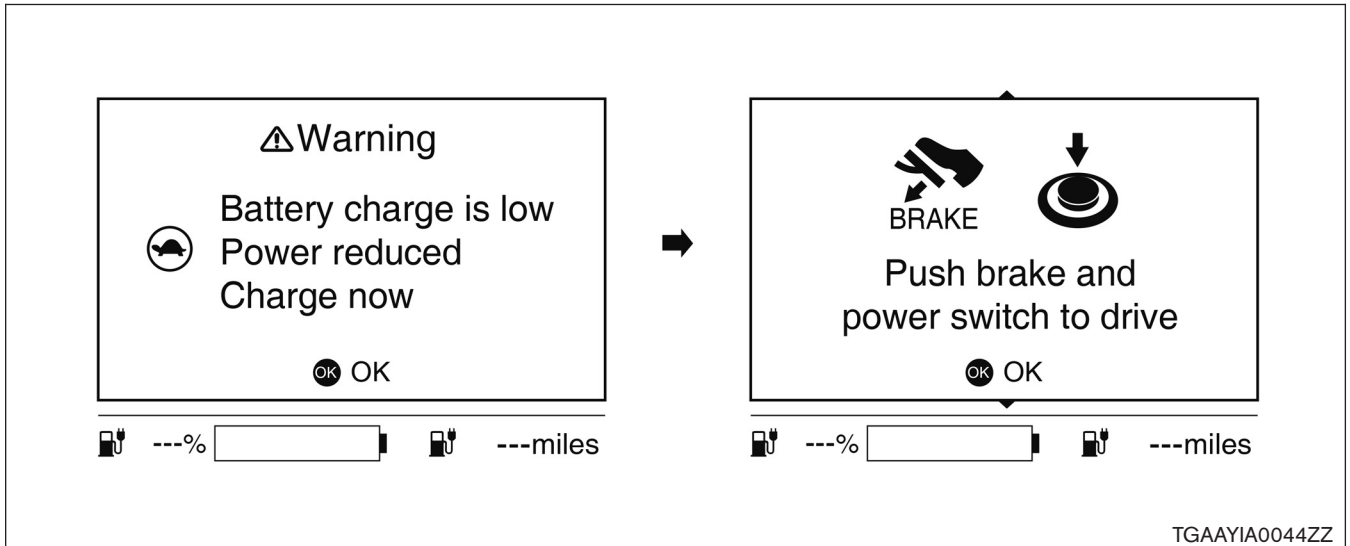





8. Press the power switch to turn the system OFF.

Please contact following number if the high-voltage battery cannot be discharged.

- Nissan EV Customer Support: 1-877-664-2738
- Nissan Consumer Affairs: 1-800-647-7261 (US) or 1-800-387-0122 (Canada)

3-2 Preparation Items

Preparation Items	Specification	Purpose
Personal Protective Equipment (PPE): Insulated gloves 	Up to 1,000V	For protection from high-voltage electrical shock
Insulated shoes 	–	
Safety shield 	–	
Leather gloves 	Must be able to fasten tight around the wrist (worn over insulated gloves).	To protect insulated gloves
Wrenches 	Size: 10mm	To remove the service plug access cover bolts. To remove the 12-volt battery terminal bolt.
Solvent resistant protection gloves Solvent resistant protection shoes	– –	To utilize in the event of a high-voltage battery electrolytic solution leak.
Absorbent pad	The same pad used for internal combustion engine fluids can be used.	To absorb any high-voltage battery electrolytic solution leakage.
Standard fire fighting equipment	Standard fire fighting equipment Depending on type of fire (vehicle or battery) use standard fire fighting equipment (water or extinguisher).	To extinguish a fire.
Insulated tape	Insulating	To cover any damaged harnesses to protect from and prevent electrical shock. Tape should cover all bare or damaged wire.

3-3 Personal Protective Equipment (PPE) and Insulated Tools

3-3.1 Personal Protective Equipment (PPE) Protective Wear Control

Perform an inspection of the Personal Protective Equipment (PPE) items before beginning work. Do not use any damaged PPE items.

3-3.2 Daily Inspection

This inspection is performed before and after use. The worker who will be using the items should perform the inspection and check for deterioration and damage.

- Insulated rubber gloves should be inspected for scratches, holes and tears. (Visual check and air leakage test)
- Insulated safety boots should be inspected for holes, damage, nails, metal pieces, wear or other problems on the soles. (Visual check)
- Insulated rubber sheet should be inspected for tears. (Visual check)

3-3.3 Insulated Tools



When performing work at locations where high-voltage is applied (such as terminals), use insulated tools meeting 1,000V/300A specifications.

3-4 High-voltage System Shut-Down Procedures



Once the high-voltage battery is properly discharged, any of the following procedures can shut down and isolate the high-voltage system. The dismantling operation can only begin after shutting down the high-voltage system. If the vehicle is heavily damaged, for example the high-voltage battery is deformed, broken or cracked, appropriate Personal Protective Equipment (PPE) must always be used and the high-voltage battery and high-voltage components must not be touched.



▲ DANGER

-  **Failure to properly shut down the high-voltage system before the dismantling procedures are performed will result in serious injury or death from electrical shock. To prevent serious injury or death, NEVER touch high-voltage harnesses or components without always wearing appropriate Personal Protective Equipment (PPE). PPE must always be worn when touching or working on high-voltage components**
-  **When contact with high-voltage components or high-voltage harnesses is unavoidable, or when there is risk of such contact, you must always wear appropriate PPE. PPE must always be worn when touching or working on high-voltage components.**

⚠ WARNING

-  If the charge connector is connected to the vehicle, remove it. Refer to [3-4.1 Removing the Charge Connector \(DG-21\)](#).
-  The vehicle contains parts that contain powerful magnets. If a person who is wearing a pacemaker or other medical device is close to these parts, the medical device may be affected by the magnets. Such persons must not perform work on the vehicle.
- Be sure to verify that the READY  indicator is off and the high-voltage system is stopped.
- After the high-voltage system is shut down, please wait at least ten (10) minutes for complete discharge of the high-voltage capacitor. While waiting, do not operate any vehicle functions.
- After shutting down the high-voltage system and removing the 12-volt battery negative (-) terminal, wait at least three (3) minutes to discharge the air bag capacitor. Even though the 12-volt battery negative (-) is disconnected, the Supplemental Restraint System (SRS) air bag maintains voltage at least three (3) minutes. During this time, there is a possibility of sudden SRS air bag inflation due to harness short circuit or damage and it may cause serious injuries.
- Always shut down the high-voltage system before disconnecting the 12-volt battery. Not doing so may result in serious injury or death from electrical shock.
- The 12V system will remain active even after the 12-volt battery negative (-) terminal is removed while the high-voltage system is active. The high-voltage system is active during any of the following conditions:
 - charging indicator is turned ON
 - READY indicator is turned ONRefer to [1-1.2 Interior Component Location \(DG-7\)](#) for location of these indicators. This is because DC/DC converter will not shut down and power will be supplied to the 12V system and high-voltage system continuously.

3-4.1 Removing the Charge Connector

NOTE:

Use the illustration to identify the type of charge connector and follow the appropriate procedure.

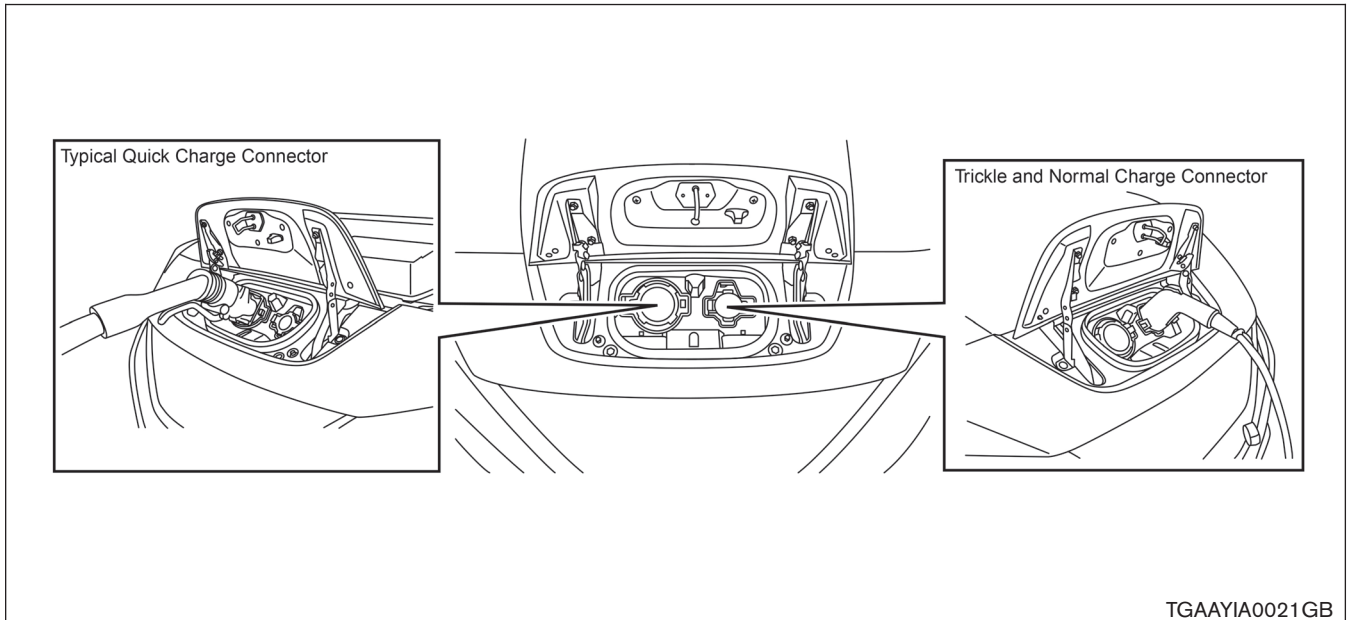

1. Quick Charge Connector (If So Equipped)

NOTE:

The quick charger must be OFF to release the charge connector lock.

Release the quick connector lock and pull to remove. Refer to the quick charger label or instructions.

2. Trickle and Normal Charge Connectors

- a. Press the charge connector release button on the charge connector and pull to remove.

NOTE:

If the charge connector cannot be removed, the electric lock is engaged. Follow the next steps to disengage.

- b. To disengage the electric charge connector lock, push the charge port lid opener switch. The charge connector will temporarily unlock for 30 seconds.

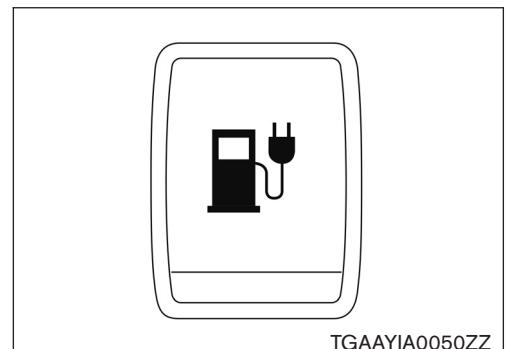

- c. The charge connector can be unlocked by pushing the charge connector unlock button on the Nissan Intelligent Key® for more than 1 second. The charge connector will temporarily unlock for 30 seconds.
- d. Press the charge connector release button and pull the charge connector to remove it.

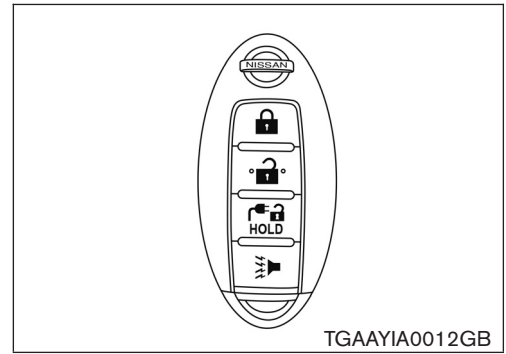

3. If the Trickle or Normal Charge Connector Cannot Unlock

- a. Place power switch in OFF position.

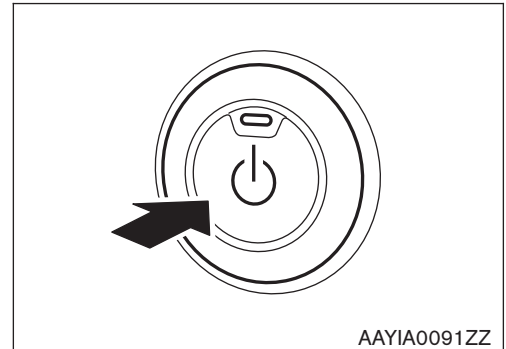

- b. Open the hood.

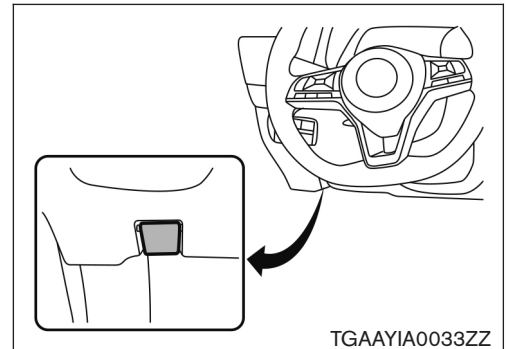

- c. Using a flat head screwdriver (or suitable tool), insert into the screw located through the access hole near the front of the hood lock.
- d. Rotate screw clockwise to release the charge connector lock.
- e. Press the charge connector release button and pull the charge connector to remove it.

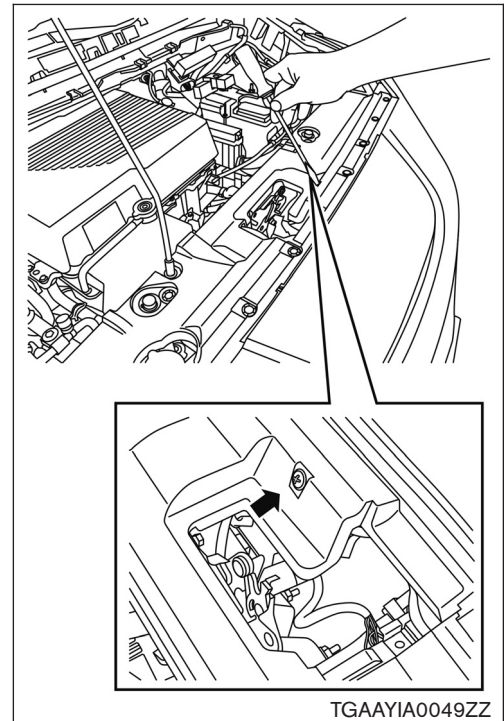

3-4.2 Indications the High-voltage System is ON

1. If the READY  indicator is ON, the high-voltage system is active.
2. The high-voltage system is active if any charge indicator is ON (blue LEDs on top of the instrument panel).

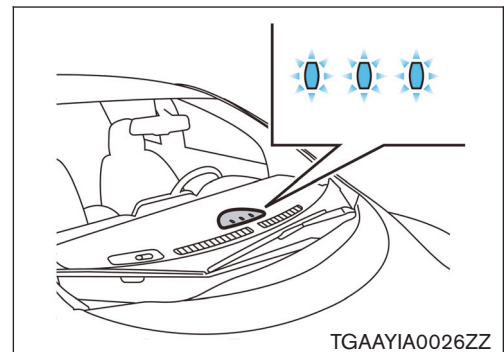



Before disconnecting the 12-volt battery terminal, if necessary, lower the windows, unlock the doors, and open the rear hatch as required. Once 12-volt battery is disconnected, power controls will not operate.

3-4.3 Powering Down the High-voltage System

The high-voltage system can be shut down with any 1 of the following procedures:

- Turn OFF the power switch **and** disconnect the 12-volt battery. Refer to [3-4.4 Primary Procedure \(DG-24\)](#).
- Remove the fuses for the high-voltage control system and disconnect the 12-volt battery. Refer to [3-4.5 Alternate Procedure 1 \(Remove Fuses\) \(DG-25\)](#).
- Remove the service plug and disconnect the 12-volt battery. Refer to [3-4.6 Alternate Procedure 2 \(Remove Service Plug\) \(DG-27\)](#).

3-4.4 Primary Procedure

1. Check the READY  indicator status. If it is ON, the high-voltage system is active.
2. Place the selector lever in the Park (P) position.
3. Press the power switch once to turn OFF the high-voltage system. Then verify whether the READY  indicator is OFF and continue to the next steps to open the hood for 12-volt battery negative cable access.

If the READY indicator does not turn off, refer to [3-4.5 Alternate Procedure 1 \(Remove Fuses\) \(DG-25\)](#).

4. If possible, keep the Nissan Intelligent Key® at least 5 meters (16 feet) away from the vehicle.

5. Open the hood.

6. Disconnect the negative (-) 12-volt battery cable (1). Insulate the negative (-) battery cable terminal with insulated tape.

NOTE:

 : Arrow in illustration depicts vehicle front direction.

7. **Wait at least ten (10) minutes for complete discharge** of the high-voltage capacitor after the power switch has been turned OFF.
8. Perform the dismantling operation.

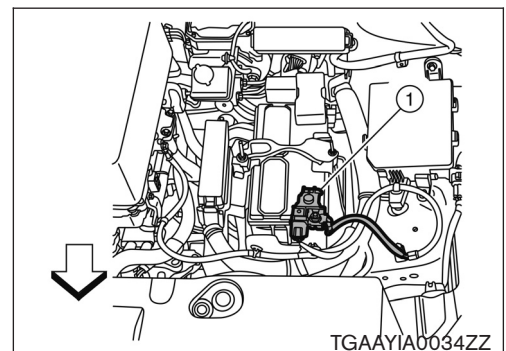
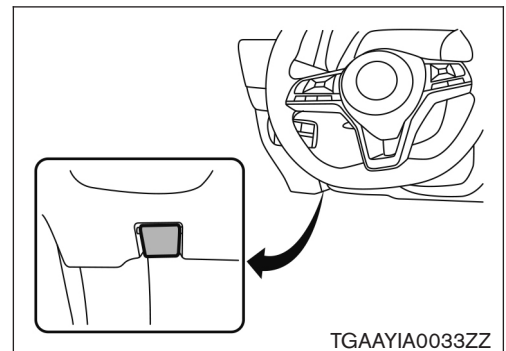
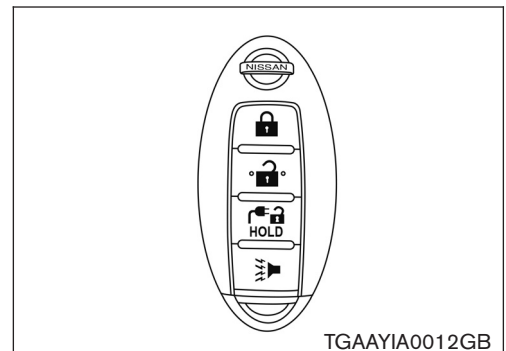
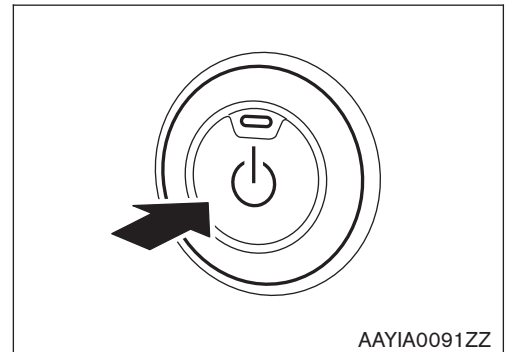

3-4.5 Alternate Procedure 1 (Remove Fuses)

1. Open the hood.

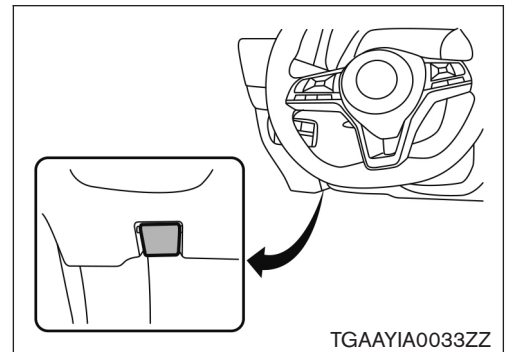

2. Press and expand the pawls (A) on the sides of the fuse box and remove the fuse box (1) from its housing.

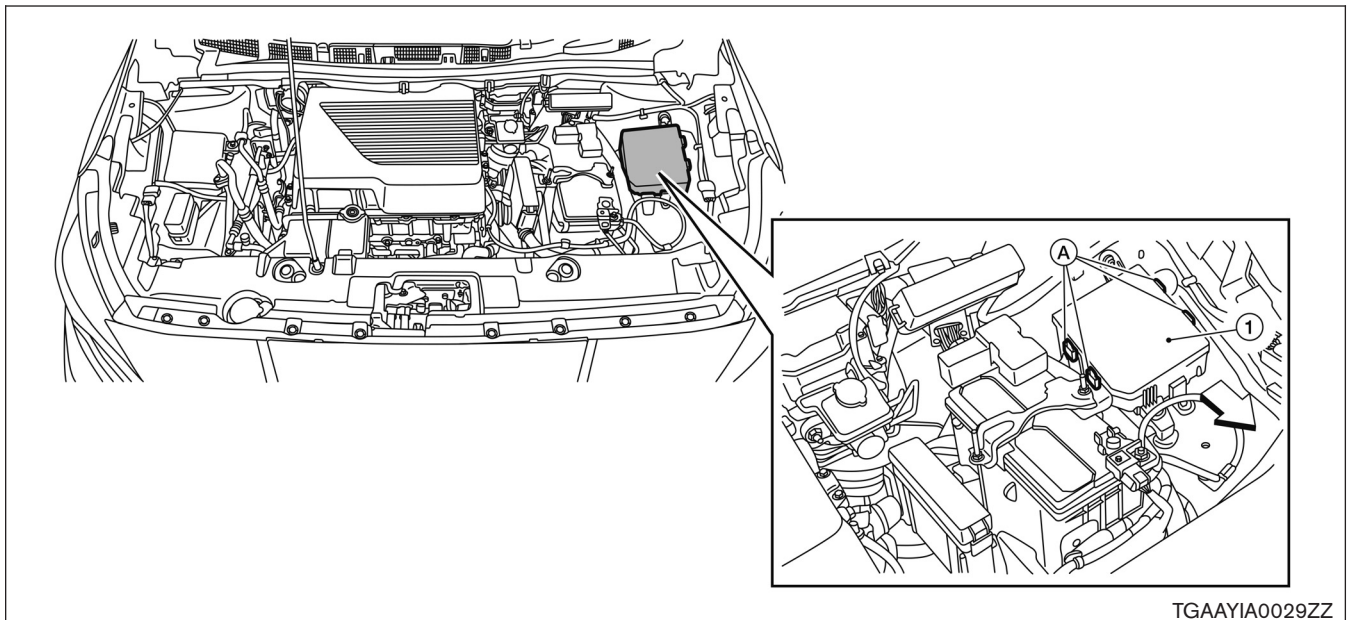

NOTE:

← : Arrow in illustration depicts vehicle front direction.

NOTE:

There is no separate fuse box cover. The bottom of the fuse box is also its cover.

3. Remove F/S1 RLY Fuse (F24 F/S1 RLY 15A).

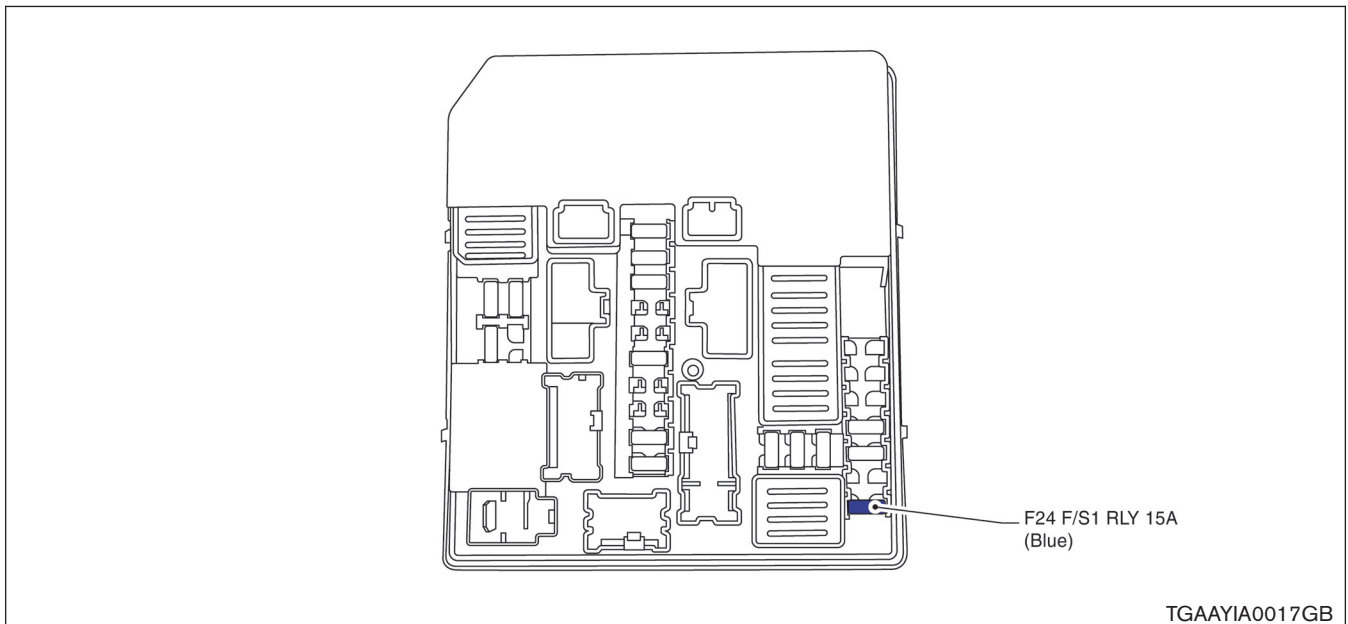

4. If you cannot identify the above fuse, remove all fuses in the fuse boxes.
5. Disconnect the negative (-) 12-volt battery cable (1). Insulate the negative (-) battery cable terminal with insulated tape.

NOTE:

↙ : Arrow in illustration depicts vehicle front direction.

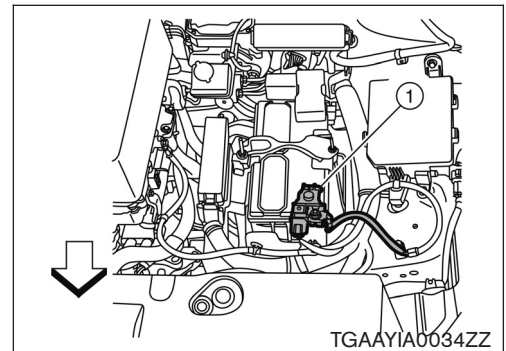

6. **Wait at least ten (10) minutes for complete discharge** of the high-voltage capacitor after the fuses are pulled.
7. Perform the dismantling operation.

⚠ WARNING

⚠ To avoid unintended reinstallation and risk of electrical shock and severe personal injury or death, the dismantler should carry the fuses on his/her person and cover the fuse box with insulated tape.

3-4.6 Alternate Procedure 2 (Remove Service Plug)



DANGER

- Do not remove the service plug without always wearing appropriate Personal Protective Equipment (PPE) to help protect the dismantler from serious injury or death by electrical shock.
- Immediately cover the service plug socket with insulated tape. The high-voltage battery retains high-voltage power even when the service plug is removed. To avoid electric shock, NEVER touch the terminals inside the socket.

WARNING



To avoid unintended reinstallation and risk of electrical shock and severe personal injury or death, the dismantler should carry the service plug on his/her person while work is in progress.

1. Insert a suitable tool (1) under the RH rear corner of the access trim cover located on the floor behind the center console. Pry up (2) and remove.

NOTE:

← : Arrow in illustration depicts vehicle front direction.

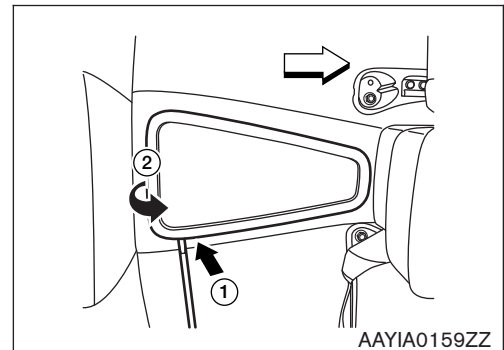

2. Remove the 10 mm access cover bolts (1) and remove the cover (2).

NOTE:

← : Arrow in illustration depicts vehicle front direction.

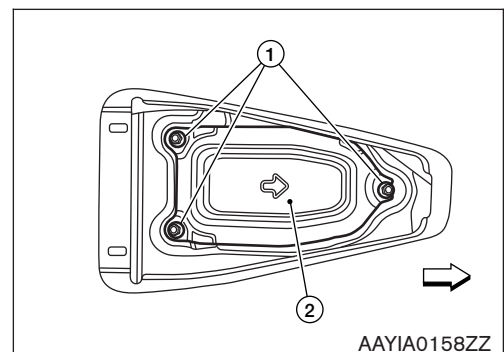

- Remove the service plug using the following steps: **(1)** pull up and release the green lever, **(2)** press the locking tab to release and rotate fully upward, **(3)** pull the service plug completely out of its socket.

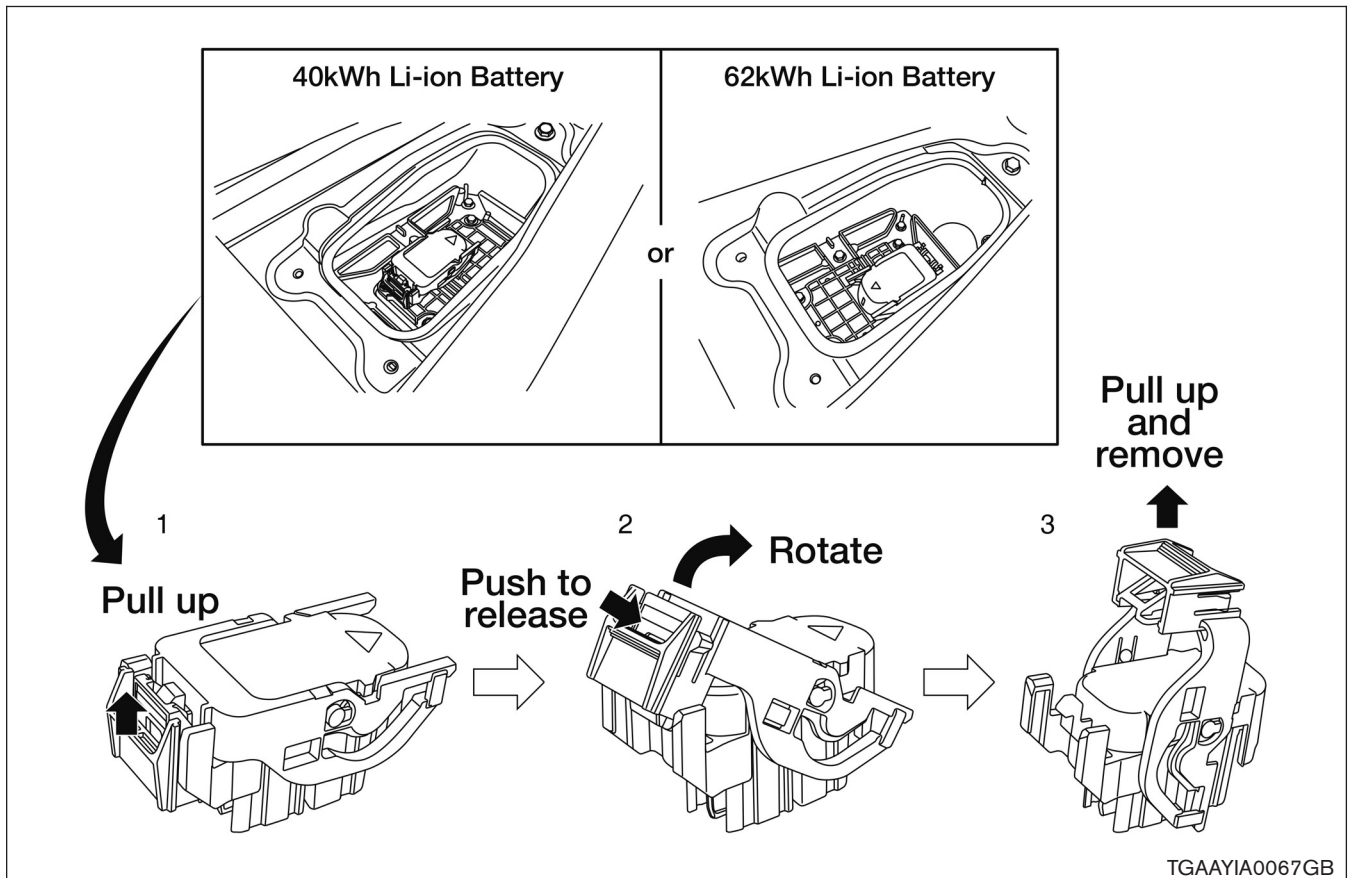

- Wait at least (10) minutes for complete discharge** of the high-voltage capacitor after the service plug has been removed.
- Open the hood.

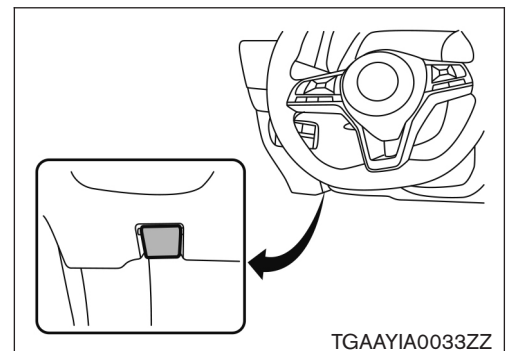

- Disconnect the negative (-) 12-volt battery cable **(1)**. Insulate the negative (-) battery cable terminal with insulated tape.

NOTE:

← : Arrow in illustration depicts vehicle front direction.

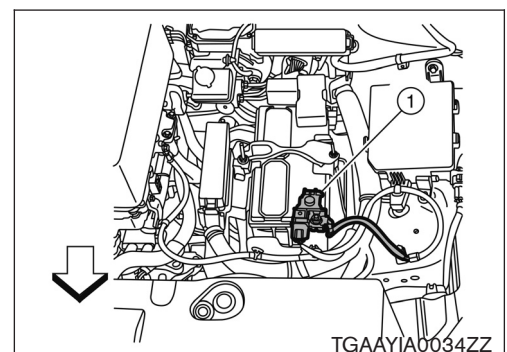

- Perform the dismantling operation.



3-5 Cutting the Vehicle Body



⚠ DANGER

-  Do not cut into high-voltage related areas to avoid severe personal injury or death.
-  Do not cut into the high-voltage battery to avoid severe personal injury or death.
-  When removing parts, **NEVER** touch the high-voltage parts or the insides of the exposed orange-colored high-voltage cables to avoid severe personal injury or death. Personal Protective Equipment (PPE) must always be worn when touching or working on high-voltage components.

⚠ WARNING

- To avoid unintended reinstallation and risk of electrical shock and severe personal injury or death, the dismantler should carry the fuses or service plug on his/her person while work is in progress.
- Do not cut air bag parts to avoid unintended deployment of the air bags and the risk of severe personal injury or death.

If at least **ten (10) minutes** have passed since the dismantler shut down the high-voltage system (refer to [3-4 High-voltage System Shut-Down Procedures \(DG-19\)](#)), then the dismantler can cut the vehicle except for the high-voltage battery.

DO NOT cut the high-voltage battery due to possible electrocution risk and electrolyte solution leakage.

3-5.1 SRS Air Bag System Components Location

The SRS air bag system and inflators must not be cut as there is a risk of short circuit and unintentional deployment of the SRS. However, the vehicle can be cut (except inflators) under the following conditions:

- The front, side and curtain air bags have deployed.
- At least three (3) minutes have passed after the 12-volt battery negative (-) cable has been disconnected and the high-voltage system has been shut down.

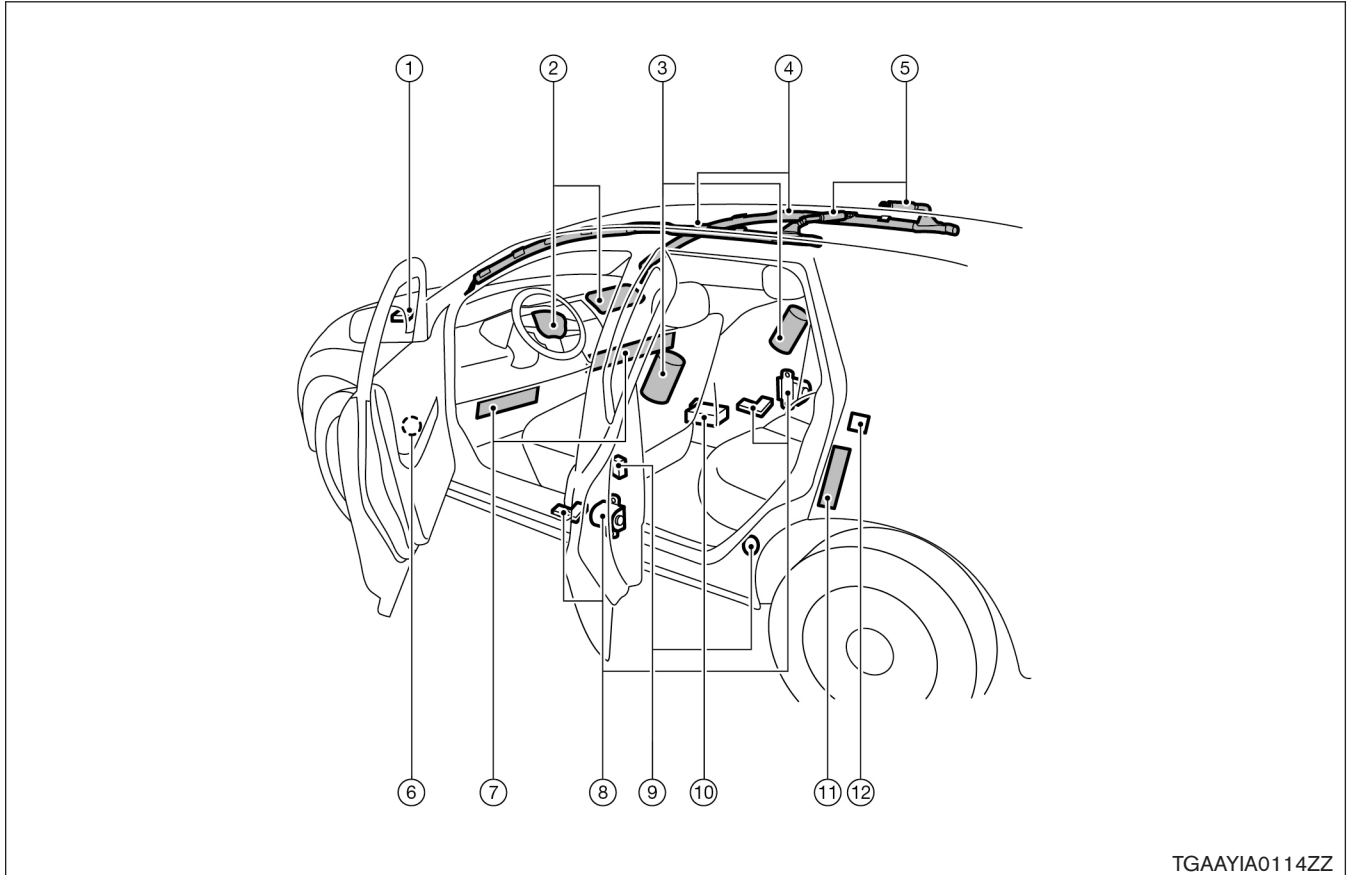

TGAAYIA0114ZZ

1. Crash zone sensor

2. Supplemental front-impact air bag modules

3. Front seat-mounted side-impact supplemental air bag modules

4. Roof-mounted curtain side-impact and rollover supplemental air bag modules

5. Roof-mounted curtain side-impact and rollover supplemental air bag inflators

6. Front door satellite sensors

7. Driver and passenger supplemental knee air bag modules

8. Seat belts with pretensioners (front seats)

9. Rear satellite sensors (located in lower B-pillars and C-pillars) (driver's side shown; passenger's side similar)

10. Air bag control unit (ACU)

11. Rear outboard seat-mounted side impact supplemental air bag modules (driver's side shown; passenger's side similar)

12. Seat belt with pretensioner (rear outboard seats) (driver's side shown; passenger's side similar)

Emergency Contact:
 Nissan EV Customer Support: 1-877-664-2738 or
 Nissan Consumer Affairs: 1-800-647-7261 (US) or 1-800-387-0122 (Canada)

Underside View Shown

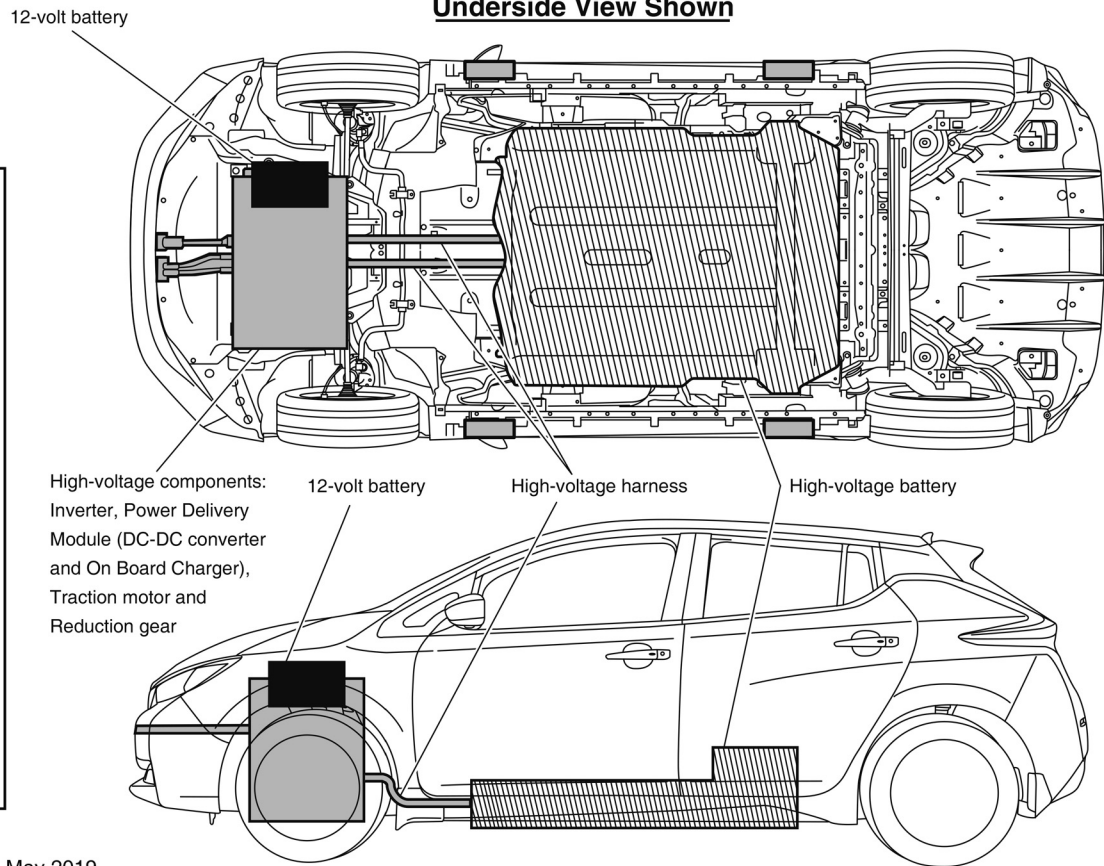

Key

■ High-voltage component or harness
 (Harness can be cut only after the high-voltage system shut down procedure has been completed.)

▨ NEVER CUT-
 High-voltage battery

■ 12-volt Battery



Never cut high-voltage components/batteries identified as "NEVER CUT" for any reason. Death or serious personal injury will result.

High-voltage components:
 Inverter, Power Delivery Module (DC-DC converter and On Board Charger), Traction motor and Reduction gear

12-volt battery

High-voltage harness

High-voltage battery

TGAAYIA0068GB

Nissan North America, Inc. Version 7, May 2019

3-5.3 Water Submersion





⚠ DANGER



Damage level of submerged vehicle may not be apparent. Handling a submerged vehicle without appropriate Personal Protective Equipment (PPE) will result in serious injury or death from electrical shock.

⚠ WARNING

-  **The power switch of the submerged vehicle must be turned OFF first, if possible. Then the vehicle must be completely out of the water and drained to avoid electrical shock.**
-  **Always wear appropriate Personal Protective Equipment (PPE) and remove/drain water before removing the service plug when working on a vehicle after a fire or submersion to avoid electrical shock.**
-  **If the vehicle is in the water, to avoid electrical shock NEVER touch the high-voltage components, harnesses or service plug. PPE must always be worn when touching or working on high-voltage components.**

3-5.4 Vehicle Fire

⚠ WARNING

- **Always utilize full Personal Protective Equipment (PPE) and self-contained breathing apparatus during fire fighting operations. Smoke from a LEAF vehicle fire is similar to smoke from a conventional vehicle fire.**
- **In the case of extinguishing a fire with water, large amounts of water from a fire hydrant (if possible) must be used. DO NOT extinguish fire with a small amount of water.**

⚠ CAUTION

In the event of a small fire, a Type ABC fire extinguisher may be used for an electrical fire caused by wiring harnesses, electrical components, etc. or oil fire.

In case of vehicle fire, contact fire department immediately and extinguish the fire if possible. If you must walk away from the vehicle, notify an appropriate responder or a rescue person of the fact that the vehicle is an electric car and contains a high-voltage system and warn all others.

3-6 High-voltage Battery Damage and Fluid Leaks

⚠ WARNING

The high-voltage battery contains electrolyte solution. To avoid exposure to electrolyte solution and serious personal injury, always wear appropriate solvent resistant Personal Protective Equipment (PPE) and read the following precautions:

- Electrolyte solution is a skin irritant – If contact with skin, rinse with plenty of water and see a doctor immediately.
- Electrolyte solution is an eye irritant – If contact with eyes, rinse with plenty of water and see a doctor immediately.
- If electrolyte leak occurs, wear appropriate solvent resistant PPE and use a dry cloth to clean up the spilled electrolyte. Be sure to adequately ventilate the area.
- Electrolyte solution is highly flammable.
- Electrolyte liquid or fumes that have come into contact with water vapors in the air will create an oxidized substance. This substance may irritate skin and eyes. In these cases, rinse with plenty of water and see a doctor immediately.
- Electrolyte fumes (when inhaled) can cause respiratory irritation and acute intoxication. Move to fresh air and wash mouth with water. See a doctor immediately.

In cases of battery case breach or electrolyte leakage, contact the fire department immediately. If you must walk away from the vehicle, notify an appropriate responder of the fact that the vehicle is an electric car and contains a high-voltage system and warn all others.

High-voltage Battery Electrolyte Solution Characteristics:

- Clear in color
- Sweet odor
- Similar viscosity to water
- Since the high-voltage battery is made up of many small sealed battery modules, electrolyte solution leakage should be minimal.

NOTE:

Other fluids in the vehicle are the same as those in a conventional internal combustion vehicle.

4. Jump Starting

To start the EV system with a booster battery, the instructions and precautions below must be followed.

⚠ WARNING

If done incorrectly, jump starting can lead to a 12-volt battery explosion, resulting in severe personal injury or death. It could also damage your vehicle.

Discharged 12-volt battery may cause the following issues:

- The instrument cluster cannot be displayed while the power switch is turned ON. The start-up sound is not audible. (The electric car system cannot start.)
- The high-voltage battery cannot be charged.
- The vehicle cannot be shifted out of PARK normally.

⚠ WARNING

-  **To avoid electrical shock, the high-voltage battery CANNOT be jump started.**
- **Explosive hydrogen gas is always present in the vicinity of the 12-volt battery. Keep all sparks and flames away from the 12-volt battery. Make sure the vent tube is correctly installed.**
- **Do not allow battery fluid to come into contact with eyes, skin, clothing or painted surfaces. Battery fluid is a corrosive sulfuric acid solution that can cause severe burns. If the fluid comes into contact with anything, immediately flush the contacted area with water.**
- **The booster battery must be rated at 12 volts. Use of an improperly rated battery can damage the vehicle.**
- **Whenever working on or near a 12-volt battery, always wear suitable eye protectors (for example, goggles or industrial safety spectacles) and remove rings, metal bands, or any other jewelry. Do not lean over the 12-volt battery when jump starting.**
- **Do not attempt to jump start a frozen battery. It could explode and cause serious injury.**
- **LEAF is equipped with an automatic cooling fan. It could come on at any time. Keep hands and other objects away from it.**
- **Always follow the jump starting instructions below. Failure to do so could result in damage to the charging system and cause personal injury.**

⚠ CAUTION

- **Do not use LEAF to jump start another vehicle.**
- **Do not attempt to perform a jump start on the 12-volt battery at the same time that the high-voltage battery is being charged. Doing so may damage the vehicle or charging equipment and could cause an injury.**

4-1 Jump Starting Procedures

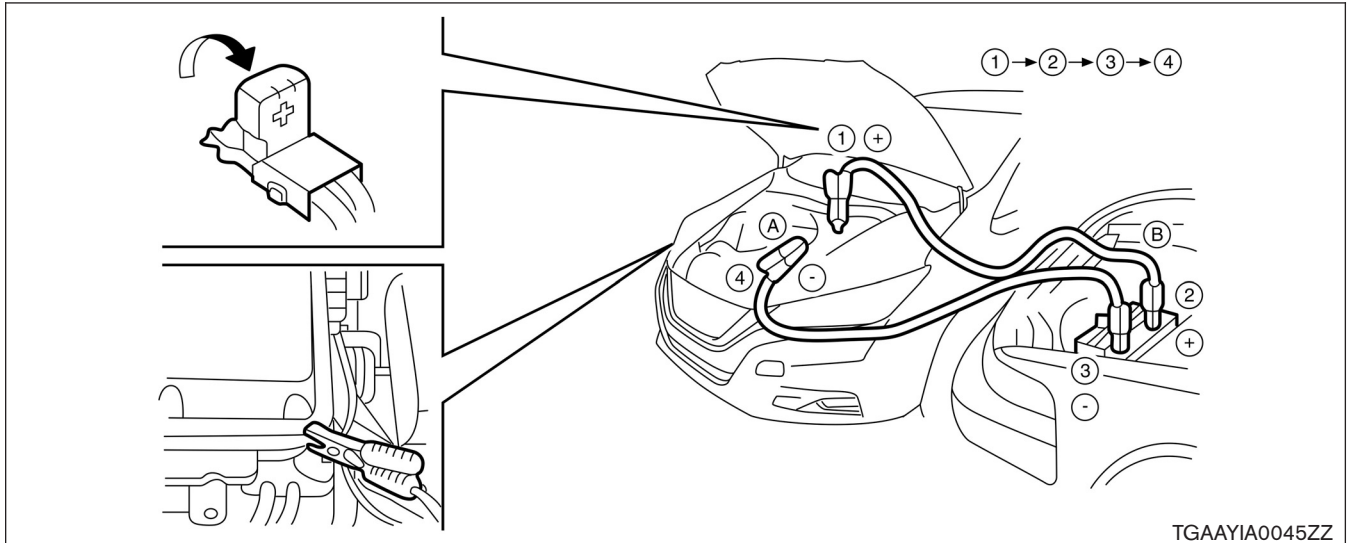

1. If the booster battery is in another vehicle (**B**), position the two vehicles (**A** and **B**) to bring their 12-volt batteries into close proximity to each other.

DO NOT allow the two vehicles to touch.

2. Apply the parking brake.

If the 12-volt battery is discharged, the power switch cannot be moved from the OFF position. Connect the jumper cables to the booster vehicle (B) before pushing the power switch.

3. Push the P (Park) position switch to place the vehicle in the P (Park) position.
4. Switch off all unnecessary electrical systems (headlights, heater, air conditioner, etc.).
5. Place the power switch in the OFF position (if possible).
6. Ensure vent caps are level and tight.
7. Connect jumper cables in the sequence as illustrated (①→②→③→④).

CAUTION

- **Always connect positive (+) to positive (+) and negative (-) to body ground (for example, as illustrated), not to the 12-volt battery.**
- **Make sure the jumper cables do not touch moving parts in the motor compartment and that the cable clamps do not contact any other metal.**

8. Start the engine of the booster vehicle (**B**).
9. While the booster vehicle (**B**) engine is running, turn the power switch ON while pressing the brake pedal in order to place the LEAF in READY  mode.

⚠ CAUTION

If the system does not start right away, push the power switch to the OFF position and wait at least 10 seconds before trying again.

10. After starting the EV system, carefully disconnect the negative cable and then the positive cable (④→③→②→①). Keep the EV system on for over twenty (20) minutes to charge the 12-volt battery.
11. If necessary, connect the vehicle to a charging station or EVSE (Electric Vehicle Supply Equipment) to charge the high-voltage battery. The vehicle cannot be driven unless the high-voltage battery is charged.

NOTE:

If it is not possible to turn the LEAF system ON by following this procedure, it is recommended you contact a NISSAN certified LEAF dealer immediately.

4-2 Electric Parking Brake Release Procedures

4-2.1 Releasing Electric Parking Brake Using Parking Brake Switch

If equipped, the electric parking brake can be released by operating the parking brake switch shown below.

1. With the power switch in the ON position, depress the brake pedal and push the switch down (1). The indicator light (A) will turn off.

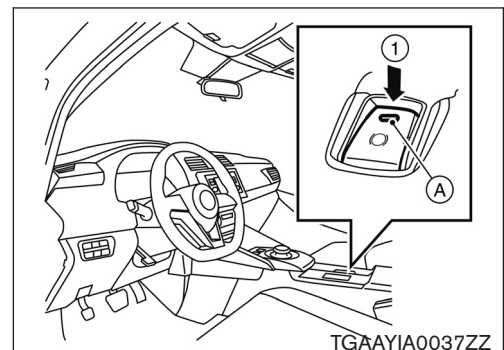

2. Check that the electric parking brake indicator light ((P) or PARK) goes out.
3. If the electric parking brake indicator light remains illuminated or parking brake cannot be released, refer to [4-2.2 Releasing Electric Parking Brake Where Parking Brake Switch Cannot Be Used \(DG-37\)](#), in this section.

4-2.2 Releasing Electric Parking Brake Where Parking Brake Switch Cannot Be Used

If the vehicle is equipped with electric parking brake and cannot be released using the parking brake switch, the following steps can be used to mechanically release the electric parking brake on each rear brake caliper assembly.

⚠ WARNING

To avoid possible personal injury or vehicle damage, use wheel chocks or take appropriate steps to prevent the vehicle from rolling freely.

⚠ WARNING

Never reuse the parking brake actuator. Doing so may cause brake system failure and possibly result in serious personal injury.

1. Disconnect the parking brake actuator harness connector (1) from the rear caliper assembly (2).

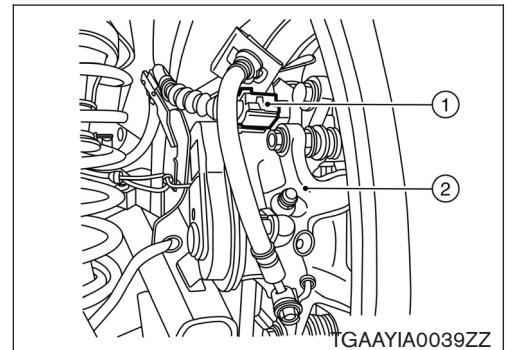

2. Remove the parking brake actuator (2) from the rear brake caliper assembly (1).

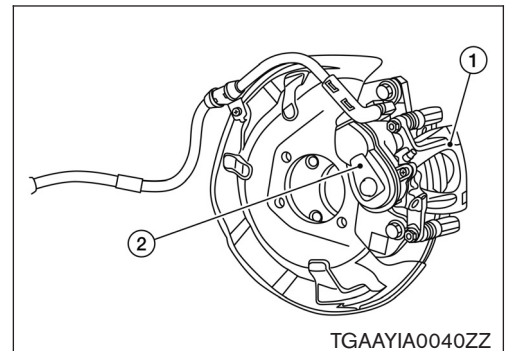

3. Rotate the rear brake caliper assembly (1) spindle part (A) clockwise to release the parking brake.

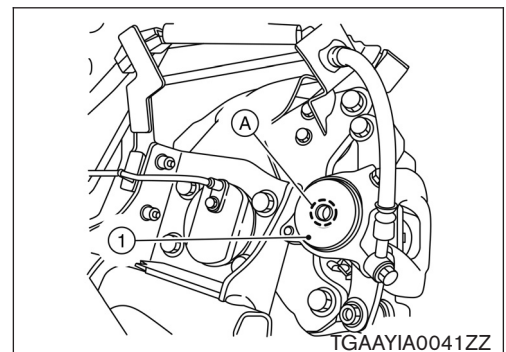

4-3 P (Park) Position Release Procedure

If you need to release the vehicle from the P (Park) position, proceed as follows. When power switch is turned OFF, LEAF automatically shifts to P position.

⚠ WARNING

To avoid possible personal injury or vehicle damage, use wheel chocks or take appropriate steps to prevent the vehicle from rolling freely.

Be sure to firmly position wheel chocks before P (Park) position is released.

1. To start the EV system with a booster battery, refer to [4. Jump Starting \(DG-34\)](#).
2. Turn power switch ON by pushing the power switch 2 times without pressing brake pedal.
3. Press and hold the brake pedal.
4. Place the selector lever in the N (Neutral) position.
5. If applied, release the parking brake.

NOTE:

If the vehicle is equipped, the electric parking brake switch will not operate after the 12-volt battery is disconnected in the next step. Be sure to release the electric parking brake before the 12-volt battery is disconnected.

6. Leave the power switch ON and disconnect the negative (-) 12-volt battery cable (1).

NOTE:

← : Arrow in illustration depicts vehicle front direction.

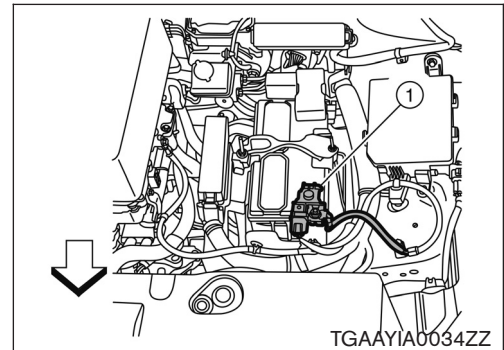

7. Be sure the vehicle is properly secured with wheel chocks and release brake pedal.

4-3.1 Reset Procedure

1. To start the EV system with a booster battery, refer to [4. Jump Starting \(DG-34\)](#).
2. Turn the power switch ON. Ensure selector lever is in the N (neutral) position.
3. Push the P (Park) position switch to place the vehicle in the P (Park) position.
4. Turn the power switch OFF.

4-4 Storing the Vehicle

⚠ WARNING

The service plug must be removed to shut down the high-voltage system for storage.

Do not store a vehicle inside a structure. Keep the vehicle away from other vehicles if the high-voltage battery is severely damaged. There is possibility of delayed fire from a severely damaged high-voltage battery.

If LEAF needs to be stored or left unattended, the high-voltage system must be shut down by removing the service plug [refer to 3-4.6 Alternate Procedure 2 (Remove Service Plug) (DG-27)] and a sign put on the vehicle indicating it is an electric vehicle with high-voltage dangers. For example:

Person in charge: _____
**DO NOT TOUCH!
IN PROGRESS.
HIGH VOLTAGE REPAIR
DANGER:**

**DANGER:
HIGH VOLTAGE REPAIR
IN PROGRESS.
DO NOT TOUCH!**
Person in charge: _____

Copy this page and put it after folding on the roof of the vehicle in service.

AAYIA0020GB





5. Dismantling Information

Removal or repair of the high-voltage battery requires special tools and specific training. Nissan strongly recommends that only NISSAN certified LEAF dealer technicians perform these operations.









5-1 Precautions for Handling High-voltage Battery



⚠ DANGER

-  Because LEAF contains a high-voltage battery, there is the risk of electric shock, electric leakage, or similar accidents if the high-voltage components or vehicle is handled incorrectly. Be sure to follow the correct work procedures when performing inspection and dismantling.
-  If it is necessary to touch any of the high-voltage harnesses or components you must always wear appropriate Personal Protective Equipment (PPE) and properly shut-down the high-voltage system by removing the service plug.
-  Be sure to always wear appropriate PPE before beginning work on the high-voltage system.
-  Be sure to remove the service plug in order to shut-down the high-voltage system before performing inspection or dismantling of high-voltage system harnesses and parts.
-  If the vehicle is heavily damaged, for example the high-voltage battery is deformed, broken, or cracked; appropriate PPE must always be used at all times to avoid electrical shock.

⚠ WARNING

-  The colors of the high-voltage harnesses and connectors are all orange. Orange "High-voltage" labels are applied to the high-voltage battery and other high-voltage devices. Do not touch the high-voltage battery or other high-voltage devices without always wearing appropriate PPE.
-  Clearly identify the persons responsible for high-voltage work and ensure that other persons do not touch the vehicle. When not working, cover high-voltage parts with an insulating cover sheet and sign or similar item to prevent other persons from contacting them.
-  Be sure to put the removed service plug in your pocket and carry it with you so another person does not accidentally reinstall it while work is in progress.
-  The high-voltage battery retains high-voltage at all times. Personal Protective Equipment (PPE) must always be worn when touching or working on high-voltage components to avoid risk of electrical shock and severe personal injury or death.
-  Immediately insulate disconnected high-voltage connectors and terminals with insulated tape.
-  The vehicle contains parts that contain powerful magnets. If a person who is wearing a pacemaker or other medical device is close to these parts, the medical device may be affected by the magnets. Such persons must not perform work on the vehicle.
-  Because this vehicle uses components that contain high-voltage and powerful magnetism, do not carry any metal products which may cause short circuits, or any magnetic media (cash cards, credit cards, etc.) which may be damaged when working on the vehicle.
-  Keep removed high-voltage battery packs away from rain to avoid electric shock.
- Do not heat removed battery packs higher than 158° F (70° C).

⚠ CAUTION

There is the possibility of a malfunction occurring if the vehicle is changed to READY  status while the service plug is removed.

5-2 High-voltage Battery Pack Removal

5-2.1 Exploded View: 40 Kwh High-voltage battery

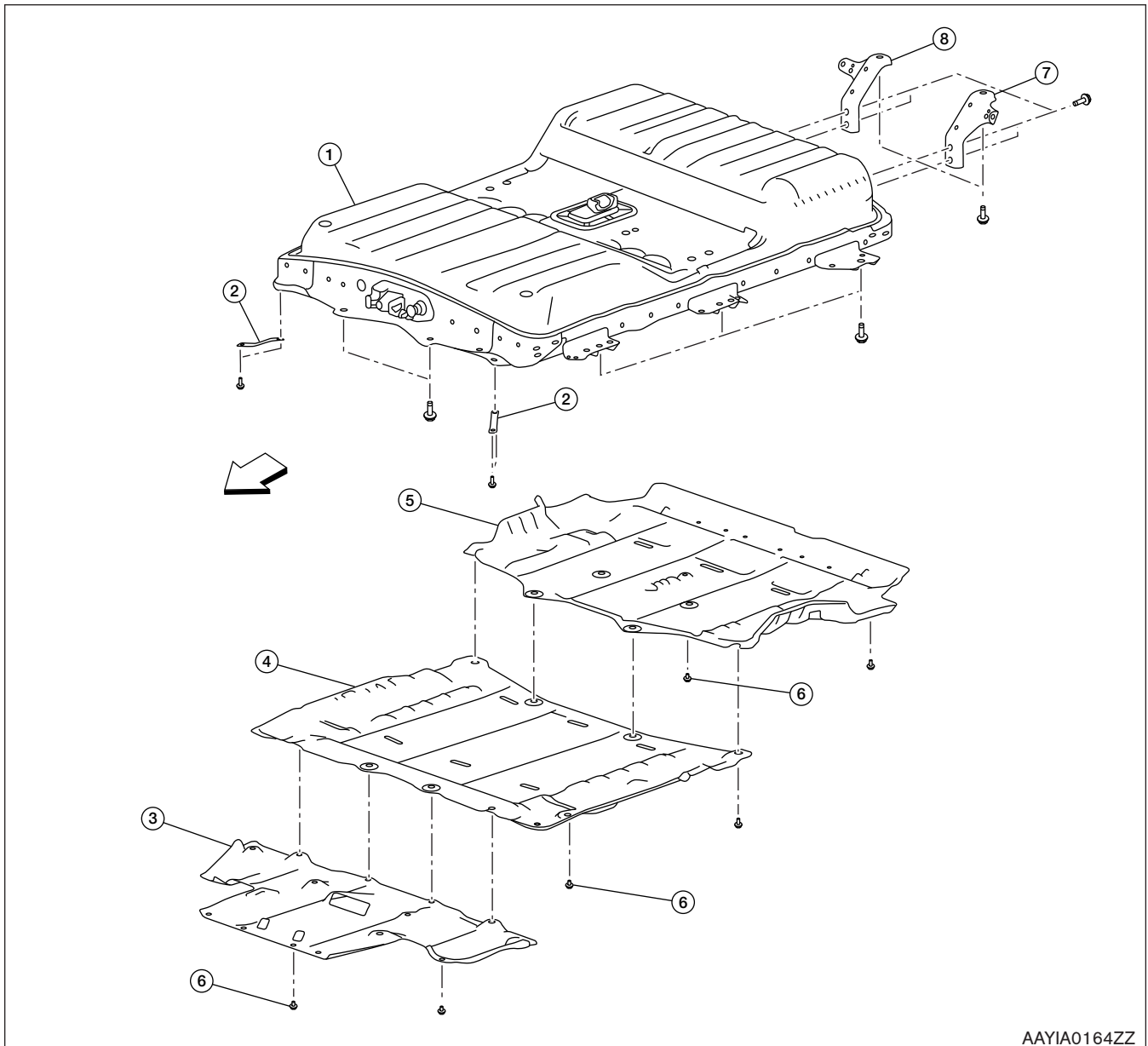

AAZIA0164ZZ

NOTE:

← : Arrow in illustration depicts vehicle front direction.

- | | | |
|--|--|---|
| 1. High-voltage battery pack | 2. Bonding plates | 3. High-voltage battery under cover (front) |
| 4. High-voltage battery under cover (center) | 5. High-voltage battery under cover (rear) | 6. Bolts and clips |
| 7. Battery mounting bracket (left) | 8. Battery mounting bracket (right) | |

5-2.2 Removal Procedure: 40 Kwh High-voltage battery



DANGER

NEVER disassemble or open the high-voltage battery to avoid severe personal injury or death by electrical shock.

1. Discharge the high-voltage battery. Refer to [3-1 Discharging Procedures \(DG-15\)](#).
2. Raise the vehicle and remove the high-voltage battery under covers (front, center and rear).
3. Remove the harness clamp (**A**) and disconnect the high-voltage harness connector (**B**) from the high-voltage battery.



DANGER

Touching high-voltage components without wearing appropriate Personal Protective Equipment (PPE) will cause electrocution.

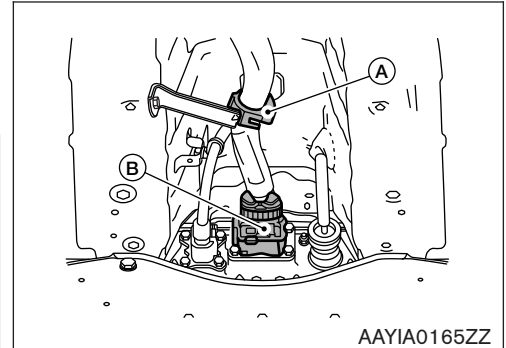

- a. Use the following instructions to disconnect the high-voltage harness connector.

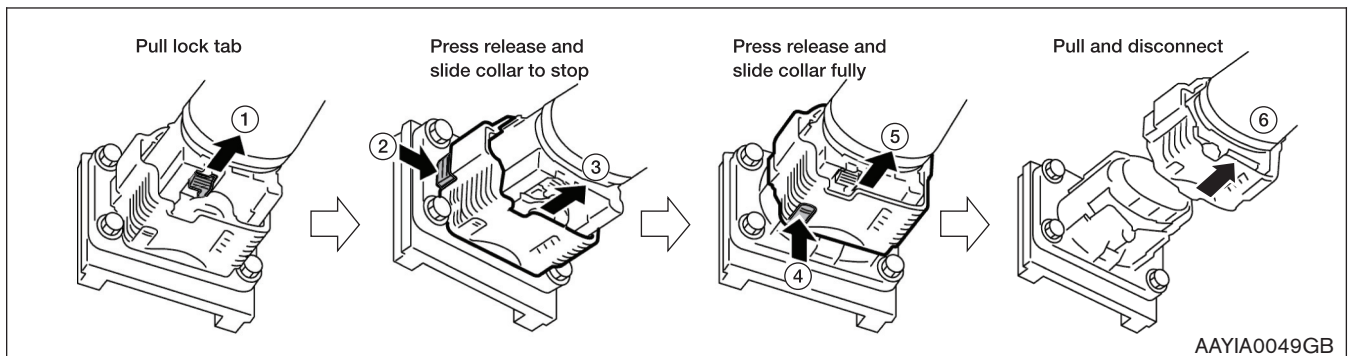

DANGER

To prevent electrocution, cover battery side of high-voltage connector with insulated tape.

 : Insulated tape

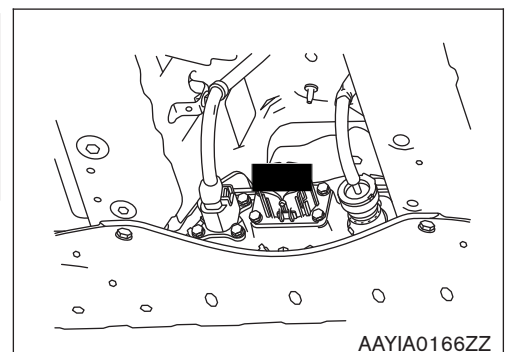

4. Disconnect the cabin heater harness connector (A) from the high-voltage battery.



DANGER

Touching high-voltage components without wearing appropriate Personal Protective Equipment (PPE) will cause electrocution.

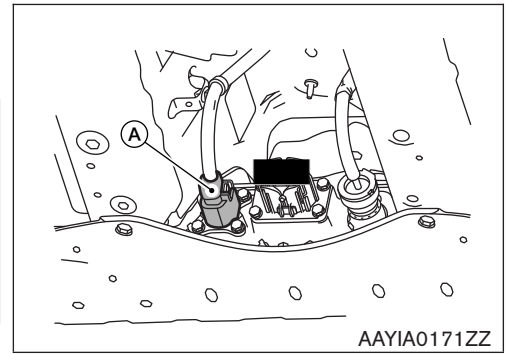

- a. Use the following instructions to disconnect the cabin heater harness connector.

Pull back lock tab

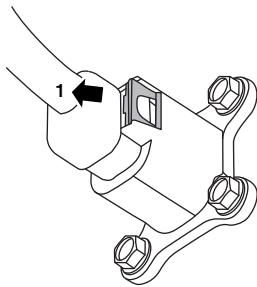

Press release and pull connector

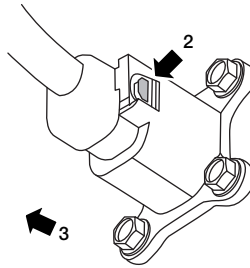

Disconnect connector

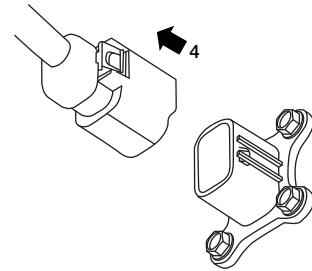

AAYIA0050GB



DANGER

To prevent electrocution, cover battery side of high-voltage connector with insulated tape.

 : Insulated tape

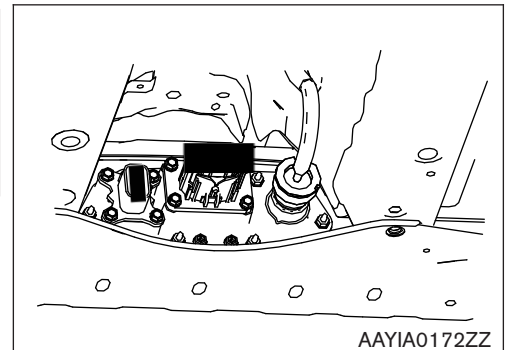

5. Disconnect the high-voltage battery vehicle communications connector (A) while turning it counterclockwise.



DANGER

Touching high-voltage components without wearing appropriate Personal Protective Equipment (PPE) will cause electrocution.

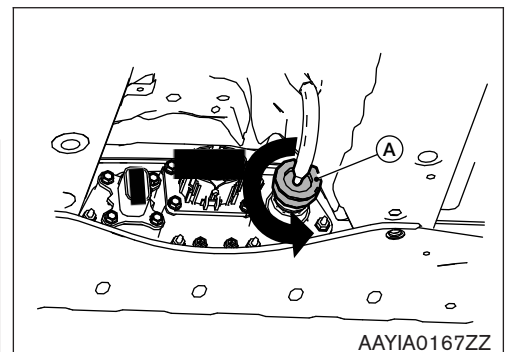

6. Remove the bonding plates (1).



DANGER

Touching high-voltage components without wearing appropriate Personal Protective Equipment (PPE) will cause electrocution.

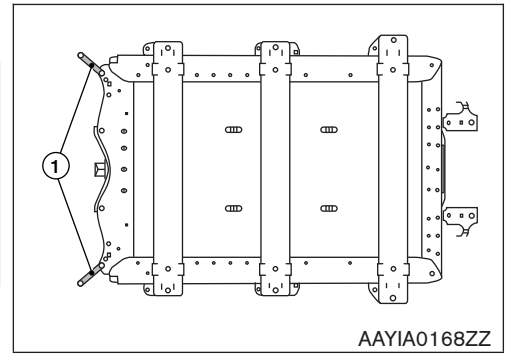

7. Remove **ONLY** the high-voltage battery mounting bolts (A) (6 bolts).

WARNING

At this stage of disassembly, **NEVER** remove the 4 bolts (B) shown in the illustration. These remaining 4 bolts will retain the high-voltage battery to the vehicle body while the lift table can be set up in the next step.

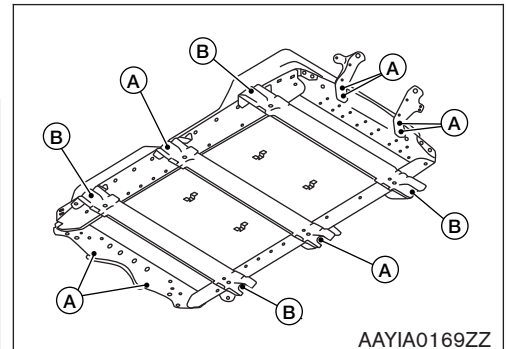

DANGER

Touching high-voltage components without wearing appropriate Personal Protective Equipment (PPE) will cause electrocution.

8. Set the pallet (1) onto the lift table (2).

- Align the pallet center mark (A) and the lifter center mark (B) (white line).



DANGER

Touching high-voltage components without wearing appropriate Personal Protective Equipment (PPE) will cause electrocution.

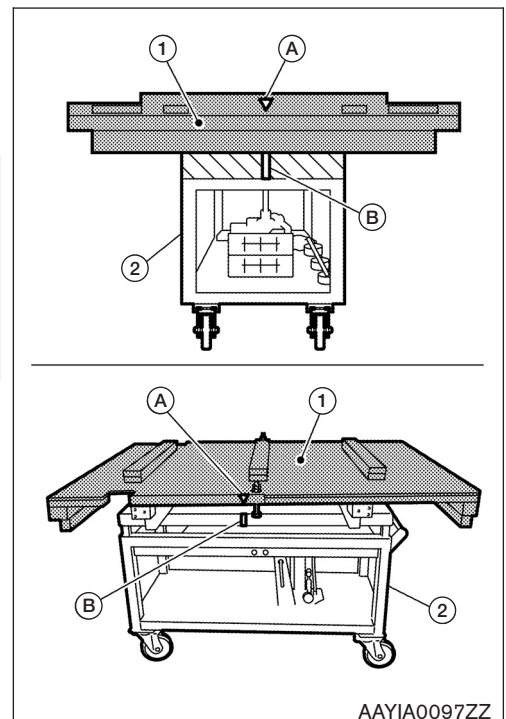

9. Set the pallet (1) under the high-voltage battery.



DANGER

Touching high-voltage components without wearing appropriate Personal Protective Equipment (PPE) will cause electrocution.

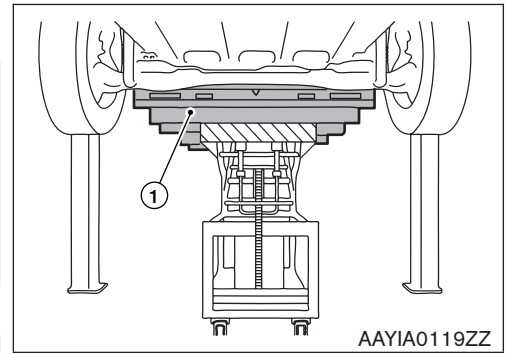

WARNING

To prevent the battery from falling and possibly result in personal injury, fasten the pallet and battery together with fastening bolts.

10. Remove the remaining 4 high-voltage battery mounting bolts (A).

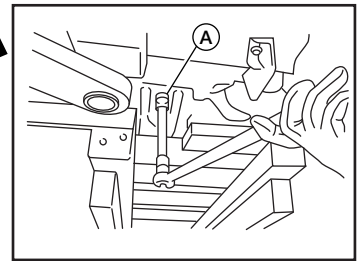
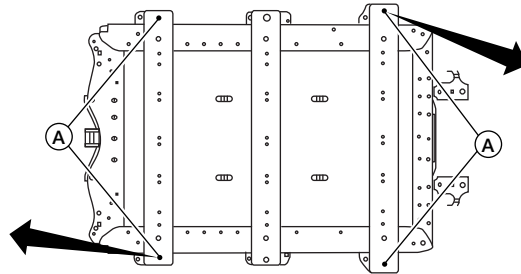
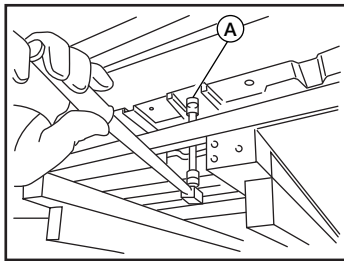

AAYIA0173ZZ



DANGER

Touching high-voltage components without wearing appropriate Personal Protective Equipment (PPE) will cause electrocution.

11. Carefully lower the pallet and remove the high-voltage battery (1) from the vehicle.



DANGER

Touching high-voltage components without wearing appropriate Personal Protective Equipment (PPE) will cause electrocution.

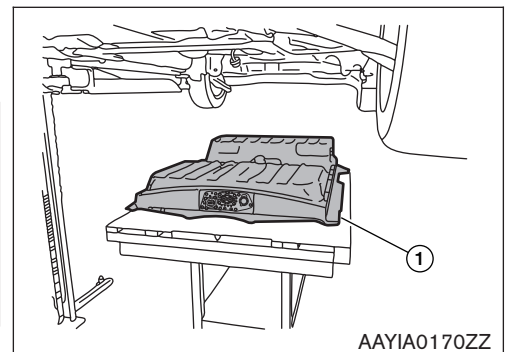

12. Lower the high-voltage battery from the lift table together with the pallet.
 - a. Lift up the high-voltage battery using a stacker.
 - b. Move the lift table.
 - c. Lower the high-voltage battery.
 - d. Operate the stacker and move the high-voltage battery.

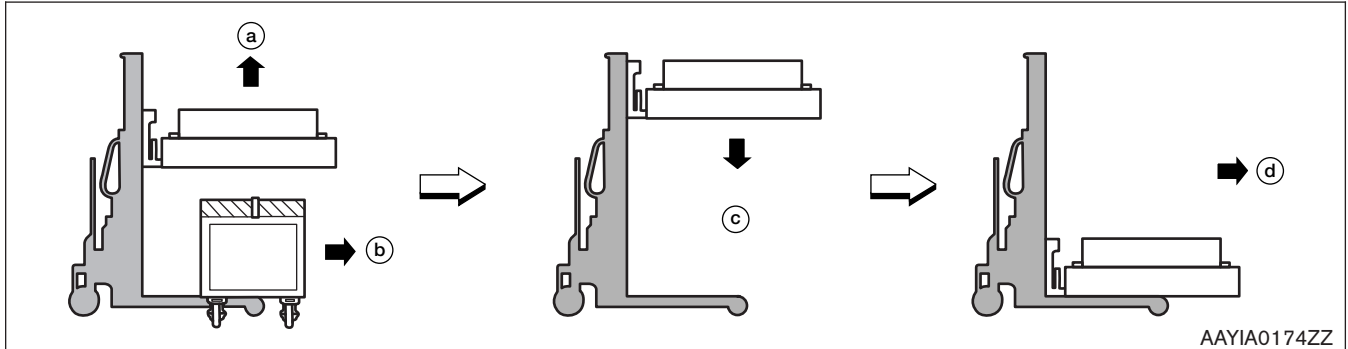

⚠ WARNING

To avoid serious personal injury, do not move the stacker while the high-voltage battery is lifted up because there is danger of tipping over.

13. Be sure service plug socket and high-voltage connectors (battery side) are covered with insulated tape.
14. Dismantling the remainder of the LEAF may be performed like conventional Nissan vehicles once the high-voltage system is properly shut down and discharged.

5-2.3 Exploded View: 62 Kwh High-voltage battery

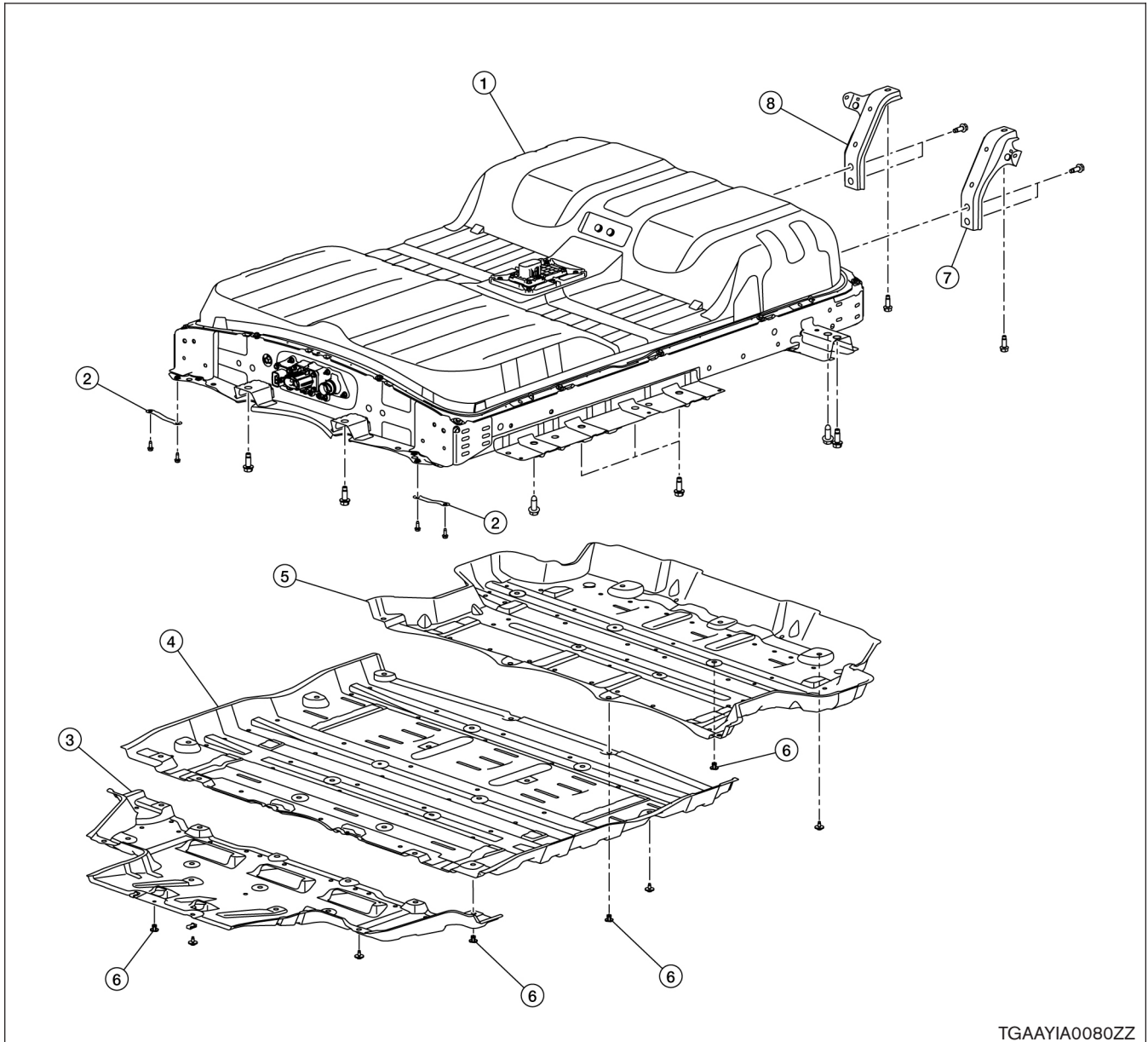

TGAAYIA0080ZZ

NOTE:

← : Arrow in illustration depicts vehicle front direction.

- | | | |
|--|--|---|
| 1. High-voltage battery pack | 2. Bonding plates | 3. High-voltage battery under cover (front) |
| 4. High-voltage battery under cover (center) | 5. High-voltage battery under cover (rear) | 6. Clip |
| 7. Battery mounting bracket (left) | 8. Battery mounting bracket (right) | |

5-2.4 Removal Procedure: 62 Kwh High-voltage battery



DANGER

NEVER disassemble or open the high-voltage battery to avoid severe personal injury or death by electrical shock.

1. Discharge the high-voltage battery. Refer to [3-1 Discharging Procedures \(DG-15\)](#).
2. Raise the vehicle and remove the high-voltage battery under covers (front, center and rear).
3. Remove the harness clamp (**A**) and disconnect the high-voltage harness connector (**B**) from the high-voltage battery.



DANGER

Touching high-voltage components without wearing appropriate Personal Protective Equipment (PPE) will cause electrocution.

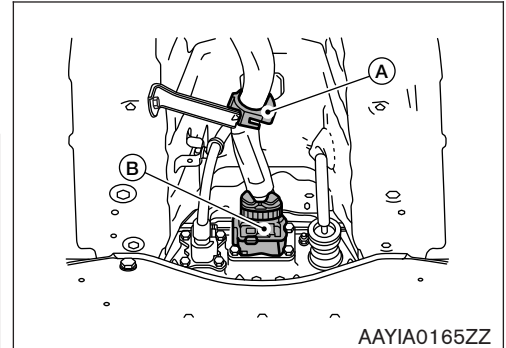

AAYIA0165ZZ

- a. Use the following instructions to disconnect the high-voltage harness connector.

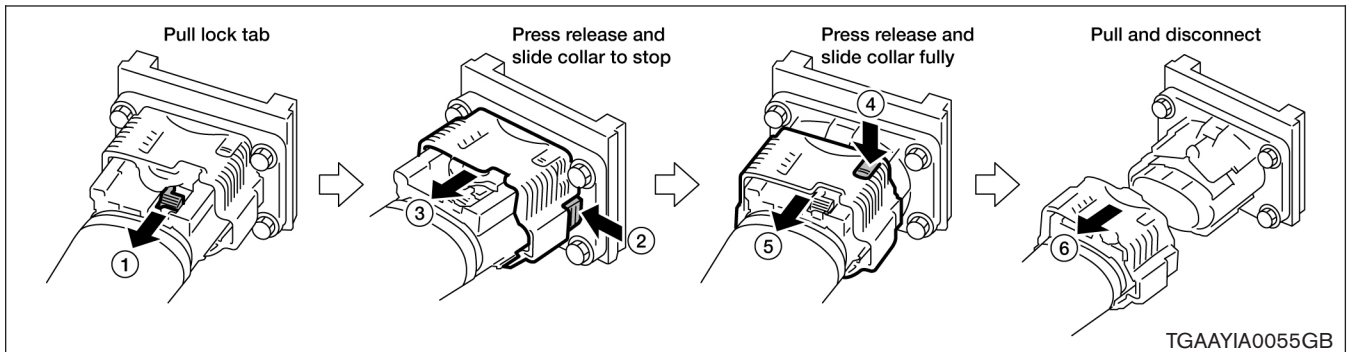

TGAAYIA0055GB



DANGER

To prevent electrocution, cover battery side of high-voltage connector with insulated tape.

 : Insulated tape

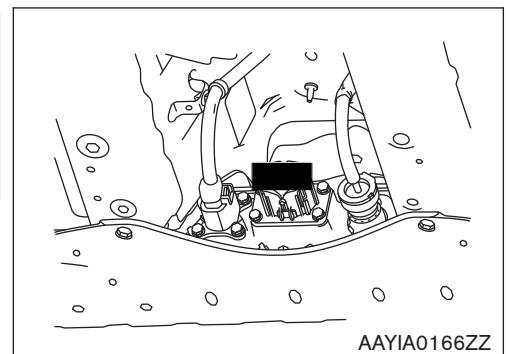

AAYIA0166ZZ

4. Disconnect the cabin heater harness connector (A) from the high-voltage battery.



DANGER

Touching high-voltage components without wearing appropriate Personal Protective Equipment (PPE) will cause electrocution.

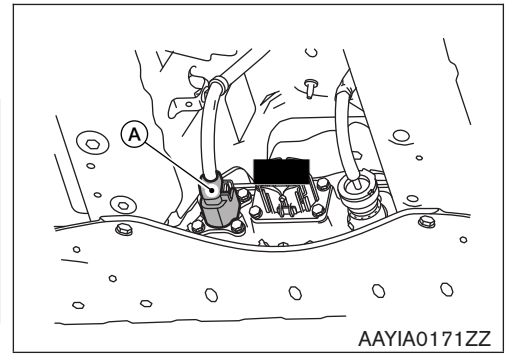

- a. Use the following instructions to disconnect the cabin heater harness connector.

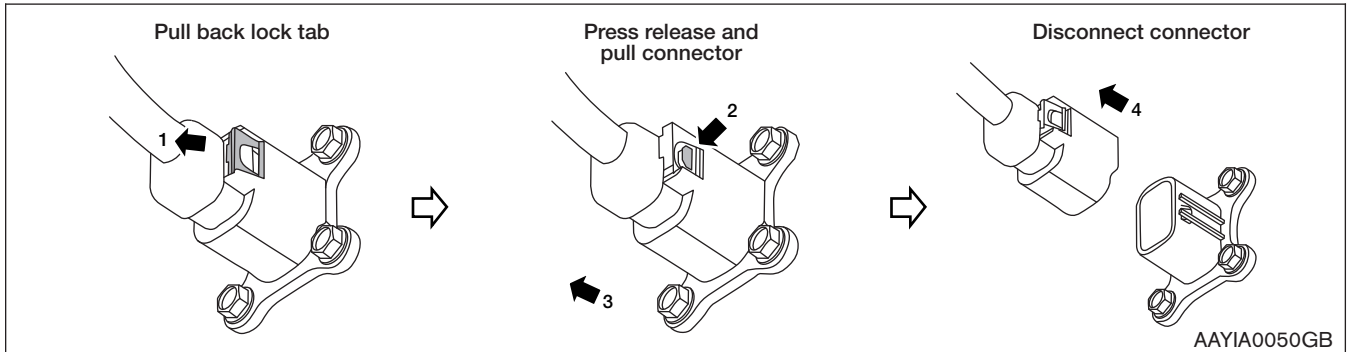

DANGER

To prevent electrocution, cover battery side of high-voltage connector with insulated tape.

 : Insulated tape

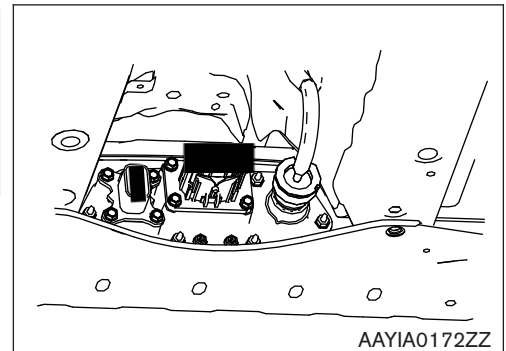

5. Disconnect the high-voltage battery vehicle communications connector (A) while turning it counterclockwise.



DANGER

Touching high-voltage components without wearing appropriate Personal Protective Equipment (PPE) will cause electrocution.

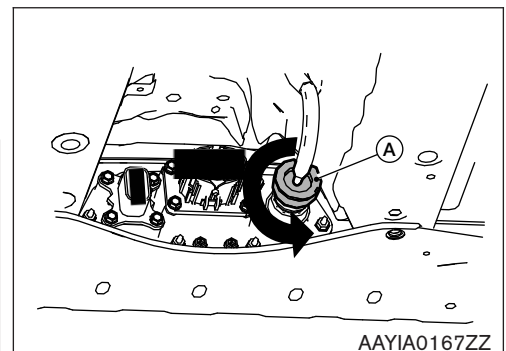

6. Remove the bonding plates (1).



DANGER

Touching high-voltage components without wearing appropriate Personal Protective Equipment (PPE) will cause electrocution.

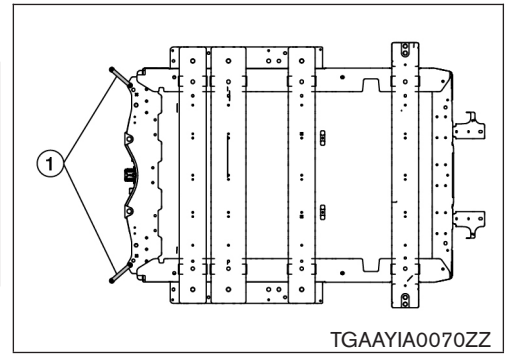

7. Remove **ONLY** the high-voltage battery mounting bolts (A) (10 bolts).

WARNING

At this stage of disassembly, **NEVER** remove the 6 bolts (B) shown in the illustration. These remaining 6 bolts will retain the high-voltage battery to the vehicle body while the lift table can be set up in the next step.

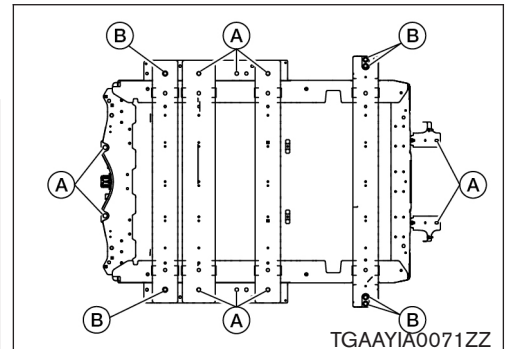

DANGER

Touching high-voltage components without wearing appropriate Personal Protective Equipment (PPE) will cause electrocution.

8. Set the lift table under the high-voltage battery.

NOTE:

C. Front of lift table

D. Side of lift table

- Align the center mark (B) of the lift table (A) with the center of gravity of the high-voltage battery (1).

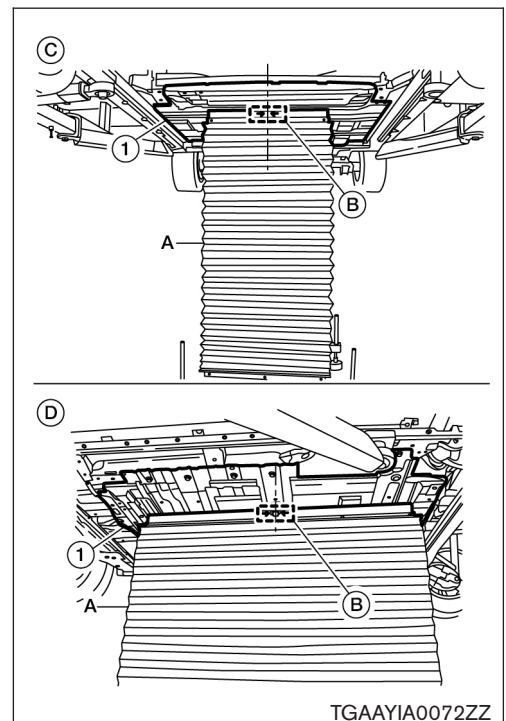

NOTE:

A. High-voltage battery center of gravity.

b. 3.62 in (92 mm)



DANGER

Touching high-voltage components without wearing appropriate Personal Protective Equipment (PPE) will cause electrocution.

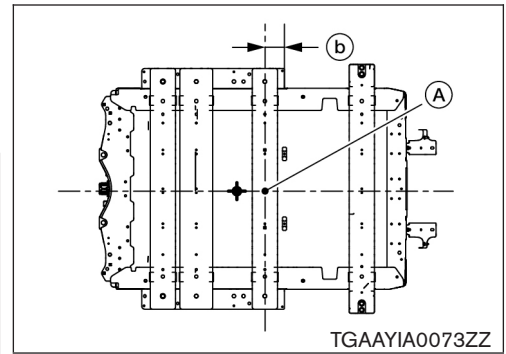

9. Remove the 6 high-voltage battery bolts [(A) two bolts] and [(B) four bolts].

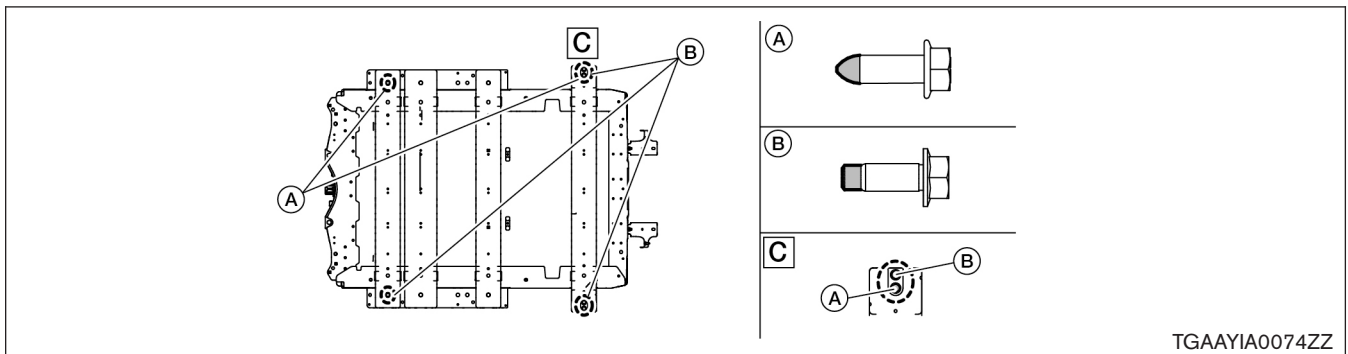

DANGER

Touching high-voltage components without wearing appropriate Personal Protective Equipment (PPE) will cause electrocution.

10. Carefully lower the lift table and remove the high-voltage battery (1) from the vehicle.



DANGER

Touching high-voltage components without wearing appropriate Personal Protective Equipment (PPE) will cause electrocution.

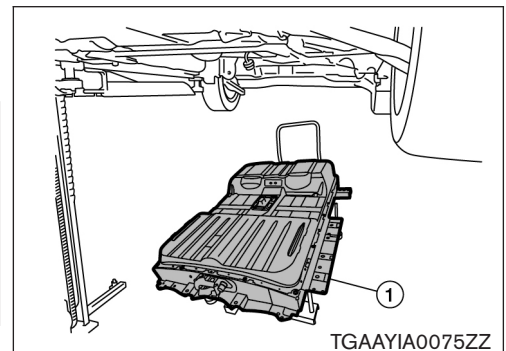

11. Follow the procedure below to remove the high-voltage battery from the lift table.
 - a. Install the eyebolt (A), washer (B) and shackle into the bolt mounting hole (C) of the high-voltage battery (1).

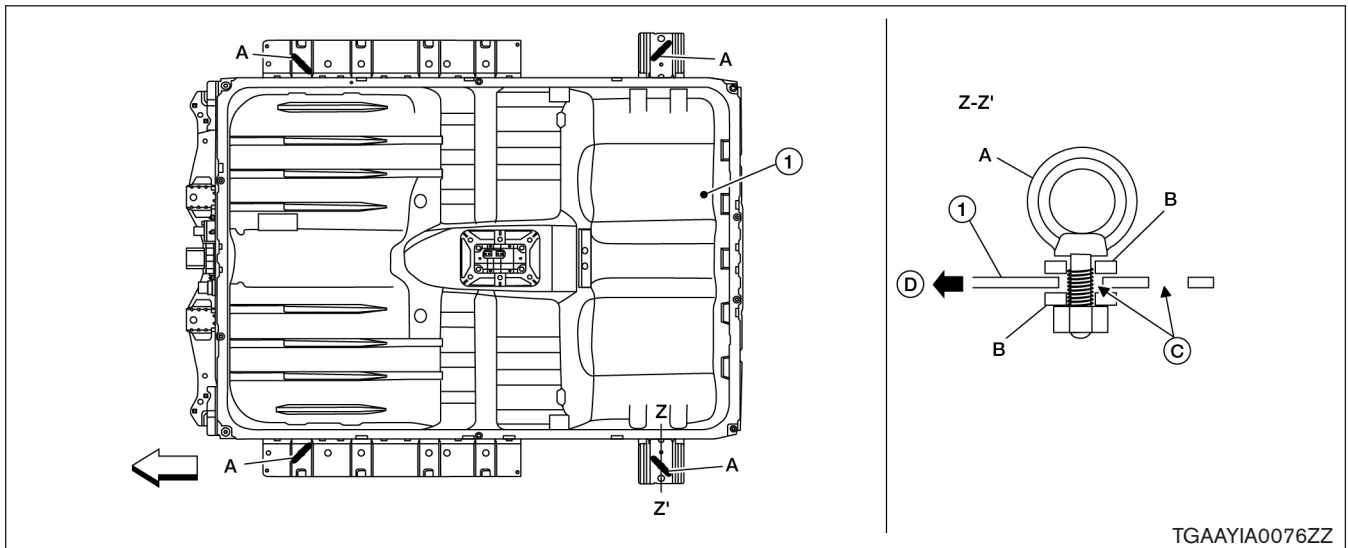

NOTE:

← : Arrow in illustration depicts vehicle front direction.

D: High-voltage battery side

- The eyebolt is attached diagonally toward the center of the high-voltage battery.
- Use the inside of the rear bolt mounting hole.

- b. Attach the sling belt (A) as shown to the high-voltage battery (1).

NOTE:

← : Arrow in illustration depicts vehicle front direction.

- c. Set the pawl of the stacker on the inside.
- d. Place the sling belt on the pawl of the stacker and lift the high-voltage battery.

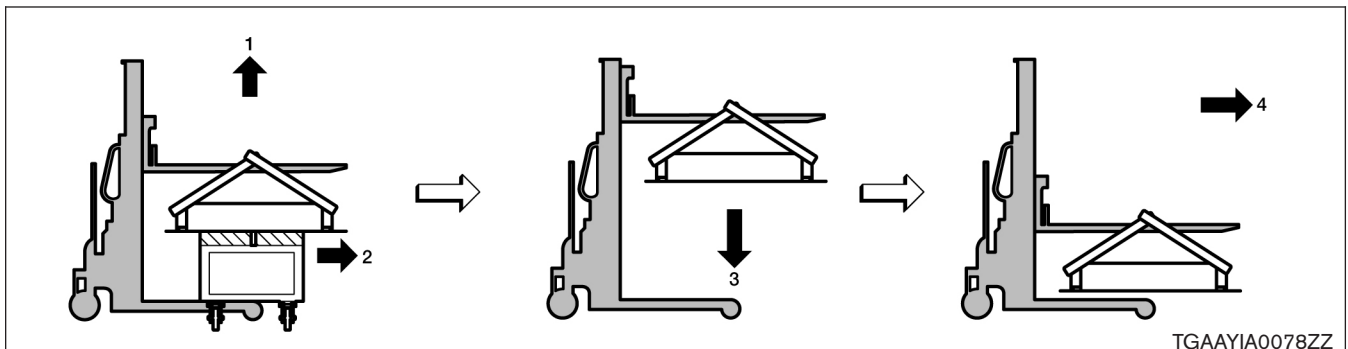
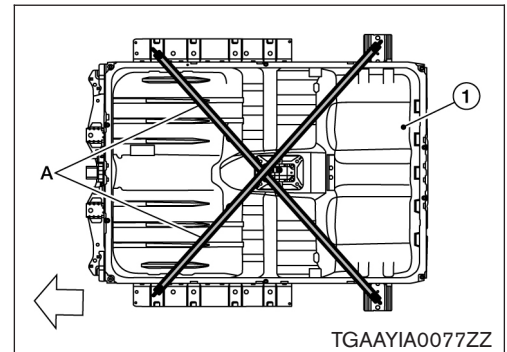

⚠ WARNING

To avoid serious personal injury, do not move the stacker while the high-voltage battery is lifted up because there is danger of tipping over.

- e. Move the lift table.
 - f. Lower the high-voltage battery.
 - g. Operate the stacker and move the high-voltage battery.
12. Lower the high-voltage battery and remove the sling belt, shackle, eye bolt and washer.

NOTE:

Make sure that piece of wood and other objects hit the position (A) in the figure of the high-voltage battery.

13. Be sure service plug socket and high-voltage connectors (battery side) are covered with insulated tape.
14. Dismantling the remainder of the LEAF may be performed like conventional Nissan vehicles once the high-voltage system is properly shut down and discharged.

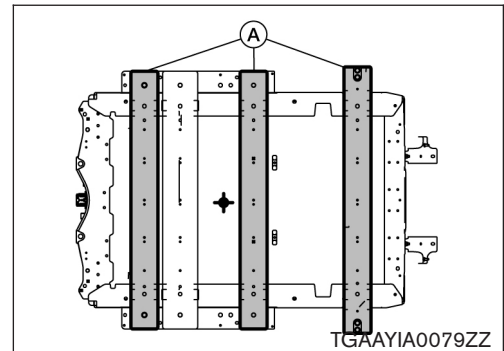

5-3 Recovery/Recycling of the High-voltage Battery

The high-voltage battery is fully recyclable. For information regarding safe recovery and recycling of the high-voltage battery, it is recommended you contact the nearest NISSAN certified LEAF dealer.

For assistance in finding your nearest dealer please call Nissan Customer Assistance at:

- Nissan EV Customer Support: 1-877-664-2738
- Nissan Consumer Affairs: 1-800-647-7261 (US) or 1-800-387-0122 (Canada)



Zero Emission

© 2020 Nissan North America, Inc.

All rights reserved.

This document may not be altered without the written permission of Nissan North America, Inc.

Pub. No. DG21EA0ZE1U0